

*walter+bai*

*w+b*

# Pendulum Impact Testers



## Impact Testing according to relevant international Standards

**In service many structural components are subjected to high loading rates or must survive high loading rates during accident conditions.**

Therefore high strain rate fracture testing is of interest and components must be designed against crack initiation under high loading rates or designed to arrest a rapidly running crack. Dynamic fracture can occur under a rapidly applied load, such as that produced by impact or by explosive detonation. Most common quality tests include methods such as the Charpy impact test and the Izod impact test. Further less common tests are the impact tension, puncture, explosive bulge test, the Robertson test, the Esso test and the Nayy tear test.

The **Charpy Impact Test** which was developed in 1905 by French scientist Georges Charpy is the most common test and widely applied in industry since it is easy to prepare and conduct and results can be obtained quickly and cheap. The specimen in the Charpy test is supported on both ends and is broken by a single blow from a pendulum that strikes the middle of the specimen on the opposite side of the notch. The specimen breaks at the notch and the pendulum passes between the two parts of the anvils. The height difference between the height of fall minus the height of rise give the amount of energy absorption involved in deforming and breaking the specimen. The use of additional instrumentation (typically an instrumented striker) allows a standard Charpy impact machine to monitor the load-time response of Charpy V-notch specimen deformation and fracturing.

The range of products w+b offers for Charpy Impact Tests are units with fixed impact work and velocity, sophisticated modular impact testers with adjustable impact work and velocity which are expandable with instrumented strain gauged striking edge with high speed data acquisition system, deformation measurement or patented laser opto-electronic-measuring-system for deflection (bending) and crack opening measurement for the experimental determination of the intensity of stress, K<sub>ID</sub>/K<sub>IC</sub>-factor with ultra high speed ADC board for data acquisition. The Izod Impact Test which was named after the English engineer Edwin Gilbert Izod who described it in the 1903 address to the British As-

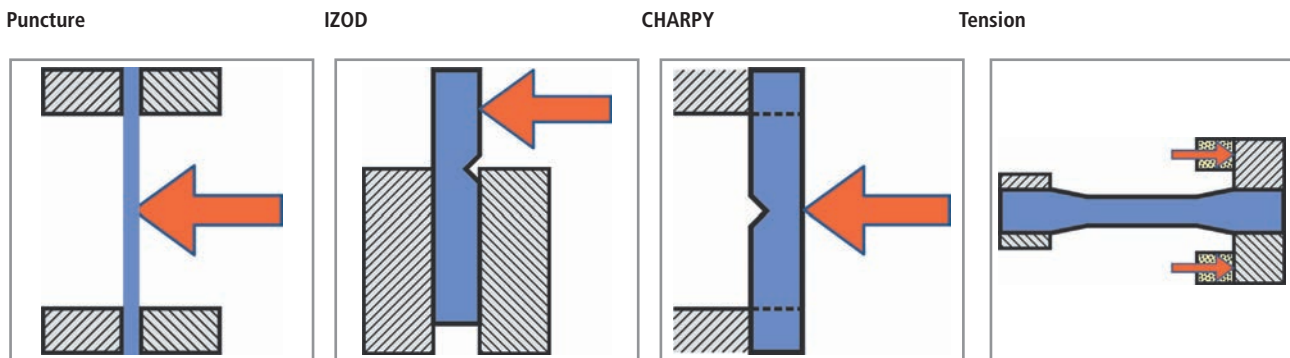

sociation is an ASTM standard method of determining impact strength using a specimen with a V-notch that is similar to the Charpy V-notch specimen. The difference is, that the specimen is gripped at one end only that allows the cantilevered end to be struck by the pendulum. These methods allow that several notches can be made in a single specimen and the ends broken off one at a time. Other types of specimen include round ones. The disadvantage is the required time to clamp the sample excludes low-temperature testing.

W+b offers Izod Pendulum Impact Testers as well as related Izod fixtures so that the Charpy Impact Tester can be used for both Charpy and Izod testing.

The method for Izod testing of steels is specified in ASTM E23: Standard Test Method for Notched Bar Impact Testing of Metallic Materials.

**The methods for Charpy testing of steels are specified in several standards including the most common used:**

- ISO 148-1: Metallic Materials - Charpy pendulum impact test
- ASTM E23: Standard Test Methods for Notched Bar Impact Testing of Metallic Materials
- GOST 9454-78: Metallic Materials - Charpy pendulum impact test
- ISO 14556: Metallic Materials - Charpy V-notch pendulum impact test - Instrumented test method
- ASTM E2298: Standard Test Method for Instrumented Impact Testing of Metallic Materials

**Relevant standards for the calibration of the Impact Testers are:**

- ASTM E23: Standard Test Methods for Notched Bar Impact Testing of Metallic Materials
- EN 10045-2: Method for the verification of Impact Testing Machines
- ISO 148-2: Verification of Test Machines

## Expandable Pendulum Impact Tester with Step-Less free Adjustable Energy/Velocity Series PH Version CHV 200 up to 900 Joule

The CHV Version of Impact Testers with adjustable energy & velocity represents a sophisticated series of modular Impact Testers expandable with instrumented strain gauged striking edge with high speed data acquisition system, patented laser opto-electronic-measuring-system for deflection (bending) and crack opening measurement for the experimental determination of the intensity of stress, KID/KIC-factor with ultra-high speed ADC board for data acquisition or robot for fully automatic testing in combination with pre-conditioning chambers or without.

The Impact Testers confirm to international standards as ISO 148-1 & ASTM E23 and are suitable for impact bending tests to CHARPY and with accessories to IZOD, Impact Tensile & Bruggen tests as well as for sub-sized & DVMK specimens.



Picture shows Model PH-450



# w+b Materials Testing Systems

The impact tester is composed of a sturdy, vibration-damping steel cast iron metallic frame with high stiffness on a lower massive structure able to ensure a steady base.

The unit is designed as symmetric U-Frame and provides easy excess for sample loading.

Ergonomically integrated digital display and operating elements for status and error messages.

Simple, fast and safe operation provided through slid able front door, easy sample centring and safe release button(s). The pendulum is automatically returned after it swung back close to its release position to safe time. Optionally automatic pendulum release mode is available when door is closed preferable ordered when tests according to ISO 148 or ASTM E23 on temperature conditioned specimens are performed which must be tested within 5 seconds since removing them from the temperature unit.

The unit can be changed rapidly from one energy range to another.

The unit can be operated as stand-alone unit with safe two hand operation or in connection with DIONIMPACT application software package.

Safety guard with acryl-glass with safety interlock-switch according to the safety regulations.

Small slidable front door for convenient sample insert and right / left side can be hinged open for easy access to change impact hammer, clean the unit, maintenance work or inspection and calibration works. The unit confirms the requirements of EC Machinery Directive 2006/42/EC and EN ISO 12100 and EN ISO 13849-1/2

## Features

- Ergonomical unit for fast and productive testing
  - Save operation complying the EC machinery directive 2006/42/EC as well as to EN ISO 12100 and EN ISO 13849-1/2
  - Versatile through step-less setting of drop height through digital display with automatic drop-height adjustment
  - Step-less adjustable energy / verlocity allows Charpy, IZOD, Impact Tensile or Brugger tests to be performed from 20%-100% of energy range and impact velocity from 2.6 m/s to 5.5 m/s
  - Fully digital unit without any analog display
  - Electronic high resolution angle-transducer (encoder), amplifier and interface board for PC with connecting cable
  - 4-digit digital display for direct absorbed energy reading with resolution 0.1 Joule
  - Interface to PC to run w+b Impact Software for custom configuring, calculation, statistical evaluation, reporting and exporting of tests and results
  - U (Box) Frame with low vibration and high mechanical stiffness
  - U-shaped hammer(s) for models up to 450 Joule and C-shaped hammer(s) for model 750 & 900 Joule with low air resistance
  - Easy specimen insertion by plier or swayable centring unit or by automatic operated specimen centring pin
  - Vibration free, safe electro-magnetic release of pendulum
  - Electric break that stops the pendulum on its highest position on the return swing for the most productive testing
  - Motorized pendulum return (hammer lifting) to the latched starting position
  - Safety guard with interlock(s) so that the test can't be started unless the guard is fully closed
  - The guard can be fully opened for maintenance or cleaning
  - Stops for fast and repeatable exchange of anvil block
  - Anvils with four usable sides so they can be turned once one side is worn out
  - Set of anvil blocks with supports to ISO EN, ASTM, DIN, ISO-V and ISO-U specimens 55x10x10 mm
  - Three modes selectable:
    - a) Manual mode
    - b) Automatic operation for productive testing and testing of temperature-conditioned specimens (tests starts automatically when the door is closed)
    - c) Service & calibration mode
  - Low friction bearings for maximum accuracy
  - Friction and windage compensation
  - Collecting tray for tested samples
  - Lifting bolts for easy transport and easy installation
  - Reference base for easy and accurate installation of the unit.
  - Including accessories to bolt the impact tester on the foundation.
  - The impact tester shall be fixed on suitable foundation.
  - Included operating manual
  - Extendable with instrumentation package with strain gauged striker, non contacting deformation measurement, ultra-high speed data acquisition system and data analysis software.
- The laser opto-electronic-measuring-system for deflection (bending) and crack opening measurement for the experimental determination of the intensity of stress, KID/KIC-factor can also be attached.





Picture shows Model PH-750

# w+b Materials Testing Systems

## Specifications

- Data Output** RS 232 for connection to PC and data acquisition software
- Weights** Different hammers weights are available to suit the different tests and the international standard.
- Power Requirements** 3 x 400 V, 50 Hz. Others upon request.

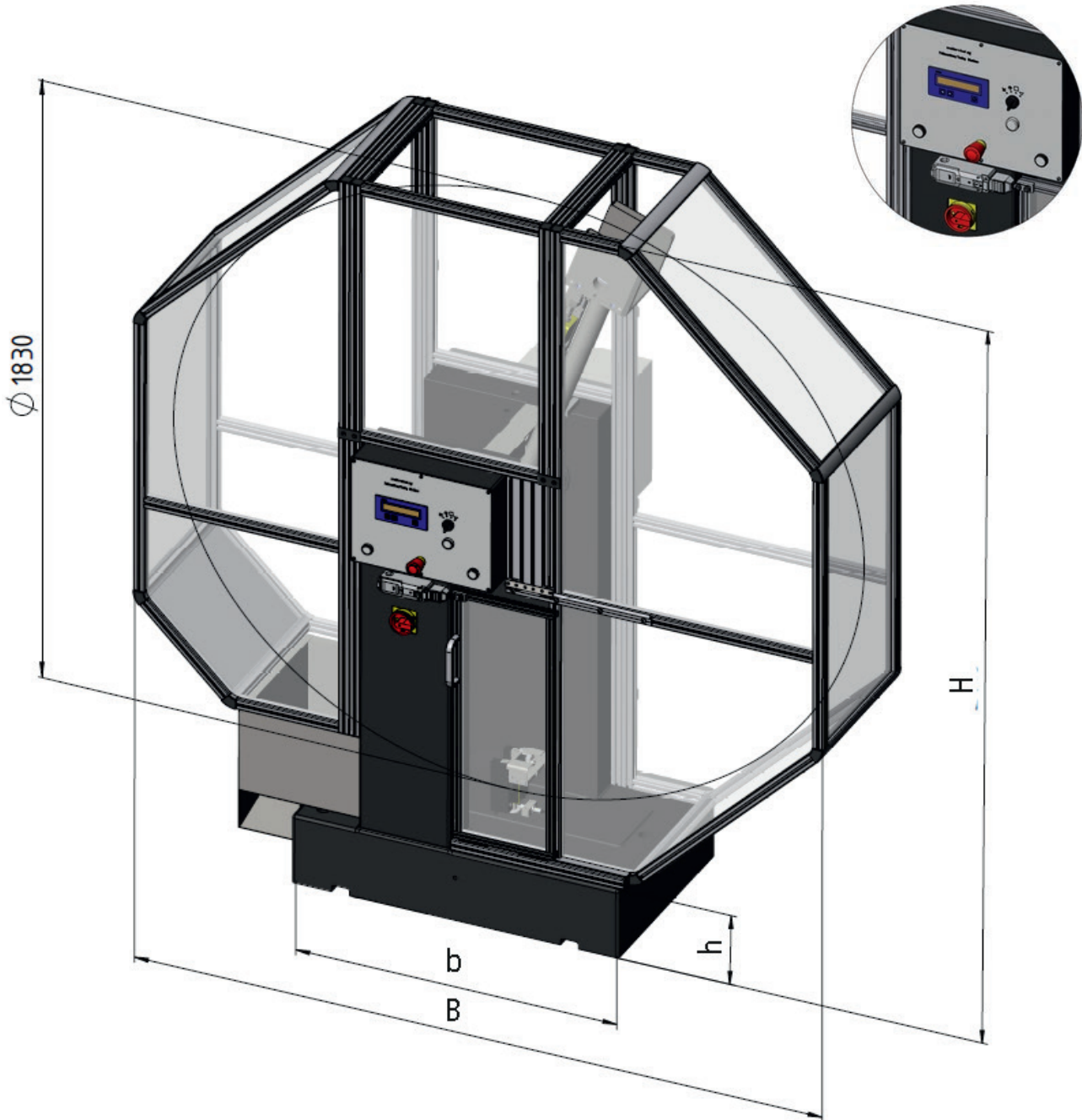

Type PH		450	750	900
Max. Impact Work	Joule	450	750	900
Available Hammer Weights	Joule	150, 300, 450	600, 750	600, 750, 900
Impact Velocity	m/sec	2.6 - 5.5	2.6 - 5.5	2.6 - 5.5
Angular of Descent	°	52.19 - 160	52.19 - 160	52.19 - 160
Width (B)	mm	1900	2180	2180
Depth	mm	850	930	930
Height (H)	mm	2050	2245	2245
Weight (without foundation)	kg	900	1780	1800

## Expandable Pendulum Impact Tester Series PH Version CHV 200 up to 75 Joule

The Impact Testers confirm to international standards as ISO 148-1 & ASTM E23 and are suitable for impact bending tests to CHARPY and with accessories to IZOD, Impact Tensile & Bruggen tests as well as for sub-sized & DVMK specimens. The unit can be expanded for instrumented testing according to ISO 14556 & ASTM E2298 as well as with laser opto-electronic-measuring-system for deflection (bending) and crack opening measurement for the experimental determination of the intensity of stress, KID/KIC-factor can also be attached.





## **Expandable Table-Top Pendulum Impact Tester with 3.8 m/sec Impact Velocity Series PH Version CHV 200 up to 50 Joule**

The Impact Testers confirm to international standards as ASTM E23, ISO 179, ISO 179-2, ASTM D6110, ISO 180, ASTM D256 or ASTM D256 and are suitable for impact bending tests to CHARPY and with accessories to IZOD, Impact Tensile & Brugger tests as well as for instrumented tests according to ISO 179-2.





## Fully Automated Robotic Charpy Impact Test Systems Series PH Version CHV 200 up to 900 Joule

Robotic pendulum impact test systems enable the increase of productivity and the reproducibility, and considered as indispensable unit at large-scale production plants as well as of quality management system. w+b offers robotic impact test systems for standard to sub-sized specimens for various temperature ranges.

This fully automatic test system is used to perform Charpy Impact Tests according to ISO 148-2, EN 10045 and ASTM E23 with temperature conditioning from -180°C to +300°C (other temperature ranges on request). The system can be used together with the PH Version CHV Series of Impact Testers.

The typical system configuration includes the barcode reader, the sample conditioning chamber, the handling robot, DION-7 IMPACT software package and connection to customer HOST system for data transmission.

Once the sample information is read by the barcode reader up to 40 (more available) Charpy specimens can be loaded into the sample magazine. After the magazine is inserted into the sample conditioning chamber the test procedure is fully automatic.

The samples are conditioned to the desired temperature, and after the soaking time has passed, they are tested within less than the required 5 seconds after removal from the chamber. The test data is transmitted automatically to the customer's HOST system.

The 6-axis robot guarantees that the thermally conditioned specimens are transferred for impact test below the required 5 seconds. The grippers of the robot remain in the specimen conditioning chamber assuring they have the same temperature as the specimens. The specimen magazine can be filled with up to 40 specimens (larger capacities are available).



# w+b Materials Testing Systems

**The Environmental Chamber** is designed for Temperatures from -180°C via LN2 up to +300°C. The specimen magazine can be entered from the front door. The specimens are picked by robot from the top through the round chamber opening (griper entry port).



During specimen feeding the top chamber opening (griper entry port) is closed by a pneumatic actuator located on the top of the environmental chamber.

The Robot with its gripper remains inside the chamber when not feeding the impact tester assuring that the feeler temperature is identical with the specimen temperature.

Temperature measurement is performed by means of thermocouple located closed to specimen.



Temperature control system is based on a Eurotherm self-tuning digital controller, providing ramp to set point capability. Construction of inner chamber is from stainless steel surrounded by high efficiency insulation.

We are offering the following Environmental Solutions:

Cooling to -70°C and Heating to +300°C with Refrigeration Chamber without LN2

Cooling to -180°C and Heating up to +300°C with Environmental Chamber with LN2 cooling

Cooling to -180°C and Heating up to +500°C with Environmental Chamber with LN2 cooling

Cooling to -180°C and Heating up to +600°C with Environmental Chamber with LN2 cooling

Cooling to -180°C and Heating up to +900°C with Environmental Chamber with LN2 cooling and additional High Temperature Furnace

**Robotic system** for safe, reliable sample handling from the environmental chamber to an impact tester with aligned sample loading and automatic start of the test within the time limit (less than 5 seconds) stipulated by international standards.

Fully automatic test procedure and data handling / storing after the samples are put into the sample magazine of environmental chamber.

The Charpy specimens are held in a revolving round magazine of capacity for up to 40 pieces, located in the middle of the environmental chamber.

The fingers of the robot (Mitsubishi 6-axis) are introduced in the climatic chamber as well, and are tempered together with samples until the desired temperature is reached, so as to avoid any temperature difference between samples and pincers of the robot.

The movement of the specimen from the climatic chamber is performed at high speed so that the delay between leaving the chamber for the load impact test is minimal.



## Specimen Gripper

The specimen grips mounted on the robot are designed to extend into the specimen magazine to pick and place the Charpy specimens. The pneumatic gripping mechanisms which is located outside of the environmental chamber is water cooled for safe operation within a wide temperature range.



## Specimen Magazine for 40 pieces

The round specimen magazine can be entered from the front door into the environmental chamber. The change is easy and quick.

Due to the different length tolerances between ISO 148 and ASTM E23 we offer individual magazines for both standards. If the specimen can be produced with more narrow tolerances one magazine for both standards would be suitable.



## Fully Automated, Robotic Charpy Impact Test System **ENHANCED**CHАРPY for Sub-Sized Samples

This fully automatic test system is optimized for ambient, low & high-temperature Charpy Impact Tests according to ISO 148-2, EN 10045 and ASTM E23 on Sub-Sized Samples.  
Available Temperature Range: -180°C to +600°C.



The typical system configuration includes the barcode reader, the sample conditioning chamber, the handling robot, **DION7IMPACT** software package and connection to customer HOST system for data transmission.

Once the sample information is read by the barcode reader up to 20 (more available) Charpy specimens can be loaded into the sample magazine.

After the magazine is inserted into the sample conditioning chamber the test procedure is fully automatic. The samples are conditioned to the

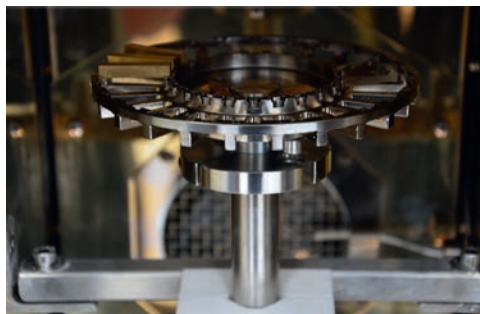

desired temperature (each sample can have individual temperature), and after the soaking time past, tested within the described 5 seconds since removal from the chamber. The test data are transmitted automatically to customers HOST system.

The fully automatic system is mounted on a base platen attached on rails to the impact tester. It allows to move it out of the test space within seconds when manual testing is desired. Additional advantage is, that it allows to upgrade existing impact testers by simple adding the automatic system.



## High Speed Data Acquisition System "ISEDA" for instrumented test according to ISO/CD 14556 & ASTM E2298

For high-resolution & high-speed data acquisition of force and (non-contacting) displacement. The data acquisition system records the following sensors:

- Position sensing diodes
- Displacement sensor
- Force sensor
- Rotary encoder

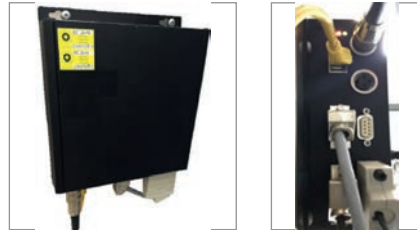

The displacement sensor and rotary encoder deliver digital signals. The position sensing diodes and force sensor deliver analogue signals which get amplified and converted. The X-Y displacement detection of the sample deformation is done using two duo-lateral PSD (Position Sensing Diodes). These two dimensional detectors deliver four small currents each which are amplified for the analogue-digital converter in the data acquisition system.

Data Acquisition Electronics and **DION7IMPACT** Software Platform  
w+b data acquisition electronics and software for impact tests according to ISO 148 & ASTM E23, instrumented test according to ISO/CD 14556 & ASTM E2298 or for the experimental determination of KID in combination with laser optical LOEMS system. The new development combines high speed- and resolution measurement system with easy to use operation. It also supports the fully automatic robotic **ENHANCEDCHARPY** systems.

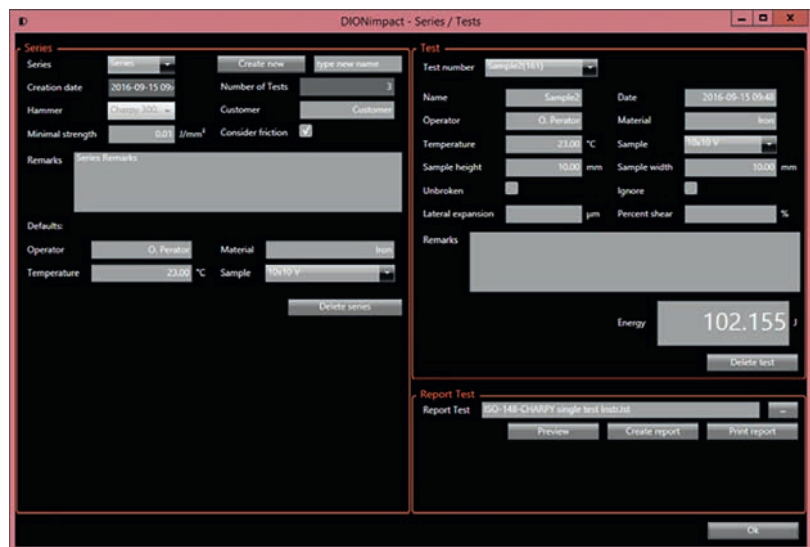
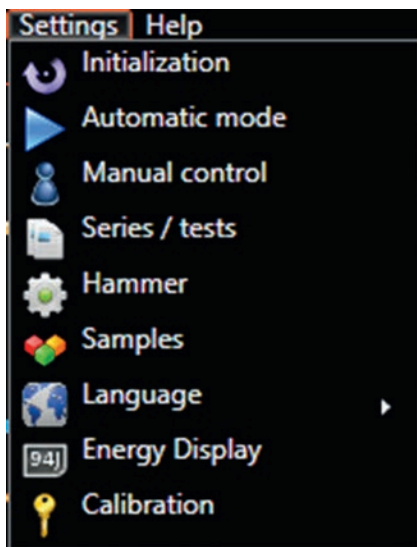

### Features

- Software Package **DIONIMPACT** for rapid and productive testing and specialised evaluation
- Intuitive software for easy operation
- Initialization procedure to compensate friction and windage
- Creation of test series
- Data management through database
- Data acquisition via high resolution angle encoder and electronics
- Automatic data storage
- Calculation of absorbed energy (J) in Joule, Impact Strength (J/mm<sup>2</sup>) and statistical evaluation of minimum / maximum / average value and standard deviation
- Data export and test report are provided with graphics like absorbed energy and energy allocation
- Software available in English, German, French, Czech, Italian and Russian

## Test Reports, Data Export and Statistical evaluation of minimum / maximum / average value and standard deviation

**DICImpact - Manual Mode**

File Settings Help

Series: Series 100 Number of tests: 2

Remarks: [Empty]

Hammer: CHASPY 25 J Customer: [Empty]

Nominal energy: 21.60 J Date: 2016-09-15 02:57

Minimal strength: 0.01 J/mm<sup>2</sup> Consider friction:

Measurement

Name: [Empty] Date: 2016-09-15 02:01

Operator: [Empty] Material: [Empty]

Temperature: 23.00 °C Sample: Sx5 V

Sample height: 5.00 mm Sample width: 5.00 mm

Unbroken:  Ignore:

Lateral expansion: [Empty] µm Percent shear: [Empty] %

Remarks: [Empty]

Current temperature: [Empty] °C Friction: 0.17 J

Energy: 0.63 J

Door operation:  Lift: [Empty] Release: [Empty]

Take defaults from series: [Empty]

Running

Print Export

Fgy	0.0000 kN
Fm	0.6170 kN
Fbf	0.5428 kN
Fa	0.3817 kN
Sgy	0.0000 mm
Sm	0.7990 mm
Sbf	1.0618 mm
Sa	1.9960 mm
Sr	3.4220 mm
Wm	0.3361 J
Wbf	0.4935 J
Wa	0.5105 J
Wt	0.6634 J

**Impact test according to ASTM E2298 (Instr.)**

Series Name: Series10

Operator: [Empty] Sample: 10x10 U (KV2)

Test Date: 12.05.2016 Temperature: 10.00°C

Print Date: 15.09.2016 Sample Height: 2.00mm

Hammer: CHASPY 25 J Sample Width: 2.00mm

Nominal Energy: 21.6 Sample Length: 10.00mm

Consider Friction: Corrected Series Remarks: [Empty]

Energy: 1.63J Fgy: 1.59kN

Fm: 2.81kN

Fbf: 2.81kN

Fa: 1.30kN

Sgy: 0.09mm

Sm: 0.95mm

Sbf: 0.95mm

Sa: 0.62mm

Wm: 1.34J

Wbf: 1.33J

Wa: 0.62mm

Wt: 1.65J

Wt: 1.29mm

Page 1 of 1

**Impact test according to ISO 148 Charpy**

Series Name: Series

Default Operator: O. Perator

Series Date: 15.09.2016

Print Date: 15.09.2016

Hammer: Charpy 300J

Nominal Energy: 300

Sample: 10x10 V (KV2)

Material: Iron

Temperature: 23.00°C

Sample Height: 10.00mm

Sample Width: 10.00mm

Sample Length: 55.00mm

Consider Friction: Corrected

Series Remarks: Series Remarks

Nr.	Sample	Energy (J)	Impact Strength (J/mm <sup>2</sup> )
1	10x10 V KV2, 23°C	90.29	1.13
2	10x10 V KV2, 23°C	102.16	1.28
3	10x10 V KV2, 23°C	97.53	1.22
	Minimum:	90.29	1.13
	Maximum:	102.16	1.28
	Average:	96.66	1.21
	Standard deviation:	5.979	0.075

**Impact test according to ASTM E2298 (Instr.)**

Series Name: Series 252

Default Operator: [Empty]

Series Date: 05.09.2016

Print Date: 15.09.2016

Hammer: CHASPY 25 J

Nominal Energy: 21.6

Sample: Sx5 V (KV2)

Material: [Empty]

Temperature: 20.00°C

Sample Height: 5.00mm

Sample Width: 5.00mm

Sample Length: 27.50mm

Consider Friction: Corrected

Series Remarks: [Empty]

Nr.	Sample	Energy Strength (J)	Fgy (kN)	Fm (kN)	Fbf (kN)	Fa (kN)	Sgy (mm)	Sm (mm)	Sbf (mm)	Sa (mm)	Sr (mm)	Wm (J)	Wbf (J)	Wa (J)	Wt (J)
1	Sx5 V KV2, 20°C	1.66	0.09	0.84	2.63	2.63	1.32	0.09	0.70	0.74	1.41	1.24	1.24	1.32	1.65
2	Sx5 V KV2, 20°C	1.84	0.09	1.60	2.57	2.57	1.20	0.15	0.76	0.82	1.70	1.45	1.45	1.57	1.98
3	Sx5 V KV2, 20°C	1.81	0.09	1.76	2.60	2.60	1.31	0.18	0.75	0.81	1.63	1.45	1.45	1.56	1.96
4	Sx5 V KV2, 20°C	2.04	0.10	1.83	2.52	2.52	1.28	0.21	0.87	0.87	1.66	1.69	1.69	1.81	2.22
	Minimum:	1.61	0.09	0.84	2.52	2.52	1.20	0.09	0.70	0.74	1.41	1.24	1.24	1.32	1.65
	Maximum:	2.04	0.10	1.83	2.63	2.63	1.32	0.21	0.87	0.87	1.66	1.69	1.69	1.81	2.22
	Average:	1.83	0.09	1.51	2.58	2.58	1.28	0.16	0.77	0.82	1.67	1.45	1.45	1.57	1.96
	Standard deviation:	0.192	0.005	0.458	0.048	0.055	0.076	0.070	0.079	0.098	0.194	0.154	0.202	0.255	

Page 1 of 1

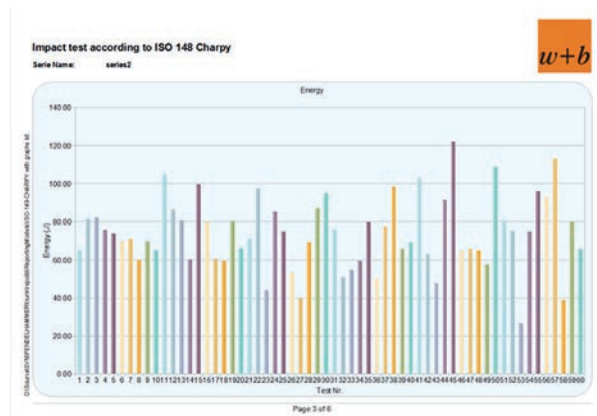
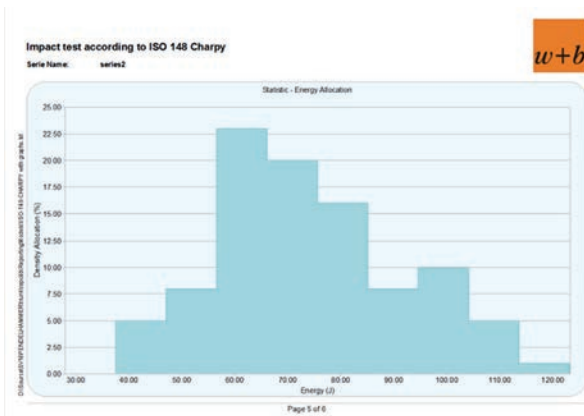

## IZOD Test according to ASTM E23

The Izod test is an impact test in which a V-notched specimen, mounted vertically, is subjected to a sudden blow delivered by the weight at the end of the pendulum arm. The energy required to break off the free end is a measure of the impact strength or toughness of the material.

The Izod impact test is similar to the Charpy impact test but differs from the Charpy impact test in that the sample is held in a cantilevered beam configuration as opposed to a three-point bending configuration.

Our IZOD support vise (specimen holding fixture) is rigid designed and clamp the specimen firmly with the centreline of the notch in the plane of the top of the vise. The IZOD vise can be mounted easily into our Charpy impact testers. The specimen fixture and striker comply with ASTM E23.



The IZOD specimen support includes the quick specimen centring device for easy specimen loading and clamping. The notch-impact strength is calculated by dividing the absorbed impact energy by the original cross section of the test specimen at the notch. Our Dion7Impact software offers easy operation, data processing & calculation, statistical evaluation, flexible test report and/or data export.



## Brugger Test

The so called Brugger Test is an impact bending test where a case-hardened specimen is struck off with a single strike of a pendulum impact tester. The test method is based on a process developed by Zahnradfabrik ZF described in the test procedure ZF 15-53.

The test lobed ends specimen is mounted in the Brugger support in such a manner that the contact surface of the striking edge hits the wide edge of the specimen fin at an angle of 30°, simulating the impact loading of a cog. To determine the toughness the test is performed with an instrumented striker. The force-time curve is recorded, and the maximum force is determined during the impact test.

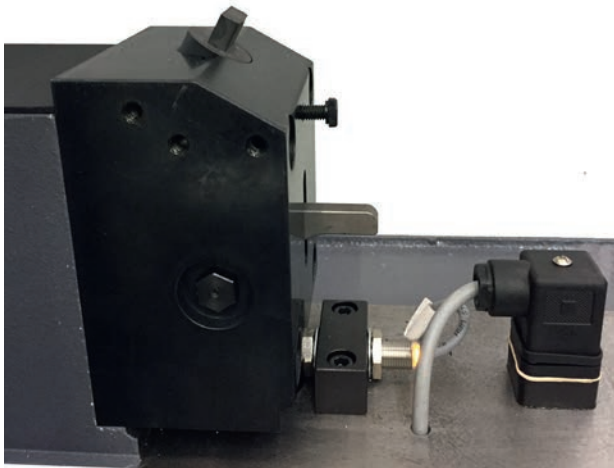

Our Brugger support is rigid designed and clamp the lobed ends specimen on its entire shaft minimizing vibrations. The specimen support with end-stop offers easy specimen loading and clamping. With our high-speed data acquisition system ISEDA and the strain gauged Brugger striker accurate force measurement is provided. The Dion7Impact Brugger application software offers easy operation, data processing & calculation, statistical evaluation, flexible test report and/or data export.



Motorized Pendulum Impact Tester  
900 Joule

## Patented Laser Opto-Electronic Measuring System LOEMS

Force, deflection (bending) and crack opening measurement or experimental determination of the intensity of stress, KID and KIC factor with ultra high speed (8 channels at 2 MHz, 14 Bit) ADC board for data acquisition. Including software package for research purposes.

The determination of the factor of intensity of distortion KIC or KID in dynamics requires the measurement of the crack opening displacement (COD) according to the applied force.

While the measurement of these two parameters, force and particularly COD, poses no problems under normal test conditions, (ambient  $T^\circ$  and slow distortion), it is not the case when the conditions become extreme, as in the case of a shock test with an impact pendulum where the use of a precision extensometer is not possible.

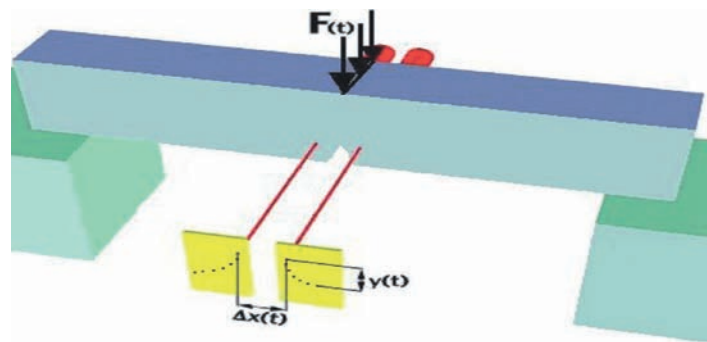

Principle of the method  
 F Force  
 Y(t) Deflection  
 X(t) COD

In order to measure the distortion during a shock test, an optical method without contact is required, permitting measurement of distortion directly on the specimen during the rupture (test time about 300  $\mu\text{s}$ ) not only in the direction of application of the force (deflection) but also in the transversal sense (COD).

A high-speed acquisition card ensures a very precise sampling range.

The principle of the method consists of drilling two very fine holes 10 mm apart at the level of the crack of the specimen, which has no influence whatsoever on the state of distortion at the level of the crack.

A laser beam of a diameter greater than that of the holes drilled in the specimen illuminates these holes.

At the moment of shock, the specimen is distorted. The holes are displaced within the illuminated area, which causes a displacement of the luminous spot emerging from the specimen onto photosensitive cells PSD \_Dual axis (Position sensitive displacement) positioned under the specimen.

These cells emit an electronic signal, depending on the location of the luminous spot, which is recorded by the acquisition card.

It is possible then to measure the distortion of the specimen simultaneously with the measurement of the applied force with distortion gauges. From the value of COD and the theory of linear mechanics of the rupture, it is possible to determine the KID.

X1, Y1 displacement of Hole 1  
 X2, Y2 displacement of Hole 2 with pendulum impact tester Series PH

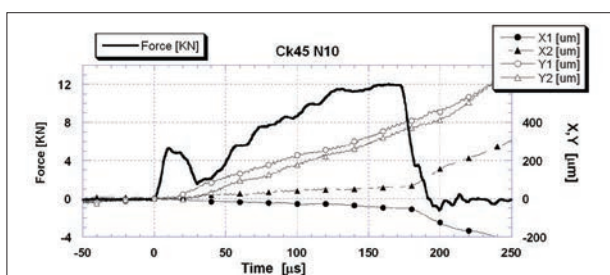

Xi COD  
 Yi Deflection  
 with pendulum impact tester Series PH

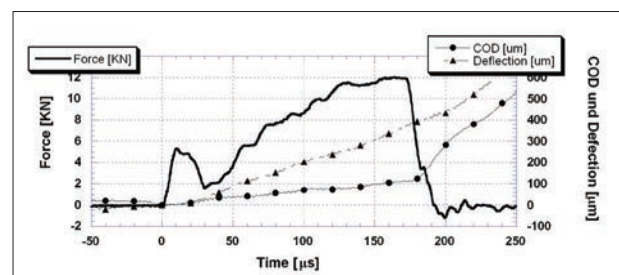

## Table-Top Pendulum Impact Tester Series PH up to 50 Joule

Versatile, extendable Table Top Pendulum Impact Tester designed for non-instrumented or instrumented tests according to Charpy, IZOD or Impact Tensile Tests. This easy to use impact tester is available in the energy range up to 50 Joule and fully comply with EN 10045-2, ASTM E23, ISO 148 and ISO 83.

Sophisticated series of modular Impact Testers expandable with instrumented strain gauged striking edge with high-speed data acquisition system, patented laser opto-electronic-measuring-system for deflection (bending) and crack opening measurement for the experimental determination of the intensity of stress, KID / KIC-factor with ultra high speed ADC board for data acquisition or pre-conditioning chambers with semi or fully automated specimen-feeding system.



### Features

- Ergonomically Table Top design
- Versatile unit with easy changeable energy range
- Safety lock to hold the pendulum in its raised position
- Vibration free release of pendulum
- Easy sample mounting by pliers or by automatic sample centering
- Electric break that stops the pendulum with Motorized pendulum return to the latched starting position
- Safety guard with interlock so that the test can not be started unless the guard is fully closed
- The guard can be fully opened for maintenance or cleaning
- Test start through software or automatic pendulum release when the door is closed for low temperature tests (<5 sec)
- Easy exchangeable strikers (EN or ASTM) and anvils
- Stiff and low-vibration design
- Low friction bearings for maximum accuracy
- Ergonomically sample tray
- Interface to PC to run w+b Impact Software for custom configuring, calculation, statistical evaluation, reporting and exporting of tests and results
- Extendable with instrumentation package with strain gauged striker, optional deformation measurement, ultra-high speed data acquisition system and data analysis software. The laser opto-electronic-measuring-system for deflection (bending) and crack opening measurement for the experimental determination of the intensity of stress, KID/KIC-factor can also be attached.



# w+b Materials Testing Systems

## Specifications

### Data Output

RS 232 for connection to PC and data acquisition software

### Weights

Different hammers weights are available to suit the different tests and the international standard.

### Power Requirements

3 x 400 V, 50 Hz. Others upon request.

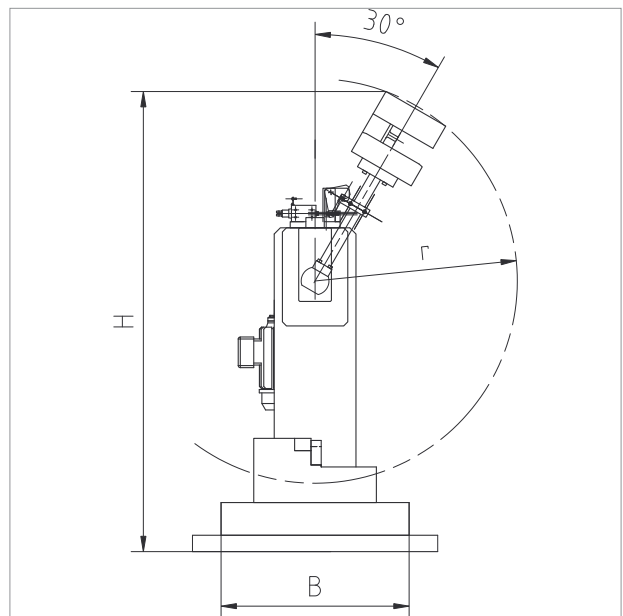
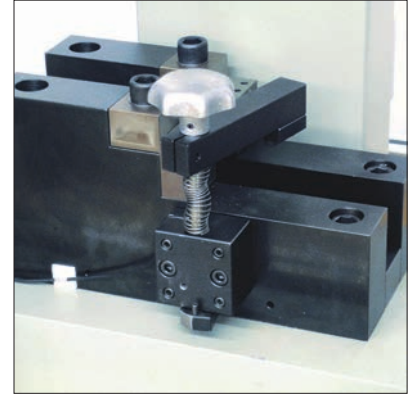
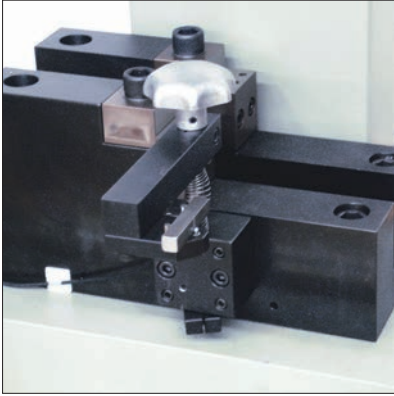

Type PH		25	50
Max. Impact Work	Joule	25	50
Available Hammer Weights	Joule	5, 7.5, 10, 25	5, 7.5, 10, 25, 50
Impact Velocity	m/sec	3.8	3.8
Angular of Descent	°	150	150
Width	mm	500	500
Depth	mm	550	550
Height	mm	1100	1100
Weight (without foundation)	kg	600	770

## Plastic Pendulum Impact Tester Series PH - P up to 50 Joule

**Advanced Pendulum Impact Tester determines the energy required to break or rupture specimens of plastics or ceramics. The apparatus conforms to all of the international test standards including ASTM D256, ISO 179 and 180 for Izod, Charpy Testing , ASTM D1822 for Tension Impact Testing and other recognised standards.**

The design utilises advanced dedicated microprocessor technology for simplicity, ease of operation, high accuracy and repeatability of results. This apparatus is extremely versatile and allows impact velocities from 1.5 m/s up to 3.8 m/s combined with variable weight hammers to give an impact energy range up to 50 Joules. A special impact energy diagnostic programme has been included to assist the operator to select the correct size of Hammer for the Standard and material being tested.

The SCADA Software enables the Tester to be controlled via the PC. SCADA allows the use of recipes to upload frequently used test parameters and combine them with a operating strategy which ensure the procedures are correctly carried out. The test parameters and operating results can be displayed on screen, printed and/or archived as standard CSV files in which can be viewed or manipulated in Excel. The apparatus also offers a Self Calibration procedure for bearing resistance and windage.



Standard features include advanced dedicated microprocessor control, Touch membrane Alpha / Numeric keypad for data entry, LCD display for sequence logic menu auto prompt selection, Yes / no mode selector, RS232 output with data transfer lead, Specview "Scada" software to allow PC control of Tester and real-time viewing of results, Self-calibration procedure, Results downloaded to PC for spreadsheet analysis, Metric units of measure, Ability to store User Names and Material Types, Recipe Manager to store and upload data, High resolution positional encoder, Variable pendulum velocity, Solenoid pendulum release with audible pre-warning, Levelling device, Full safety guarding electrically inhibiting operation when not closed, Fully traceable certificate of calibration, Product user manual, CE mark of conformity. Optional accessories available: variable Weight Hammers for Izod, Charpy or Tension Impact, Izod, Charpy or Tension Impact Clamps & Vices, Special clamps, fixtures and hammers for component testing, Guard Enclosure.

Complies with Standards: ISO 180, ISO 179, DIN 51222, BS 2782: Part 3: Method 359, BS 2782: Part 3: Method 350, ASTM D5942, ASTM D5941, ASTM D256, ASTM D1822

### Specifications

<b>Data Output</b>	RS 232 for connection to PC and data acquisition software
<b>Weights</b>	Different hammers weights are available to suit the different tests and the international standard.
<b>Power Requirements</b>	230 V, 50 Hz. Others upon request.

Type PH		25	50
Max. Impact Work	Joule	25	50
Available IZOD Hammer Weights	Joule	1, 2.75, 5.5, 11, 22	1, 2.75, 5.5, 11, 22
Available CHARPY Hammer Weights	Joule	0.5, 1, 2, 4, 5, 7.5, 15, 25	0.5, 1, 2, 4, 5, 7.5, 15, 25, 50
Impact Velocity	m/sec	1.5 - 3.8	1.5 - 3.8
Angular of Descent	°	30 - 165	30 - 165
Width	mm	950	950
Depth	mm	850	850
Height	mm	600	600
Weight	kg	115	130

## Cooling chamber Series CharpyTemp

### CharpyTemp

### Low Temperature Bath for Charpy Impact Specimens



Specifications		CharpyTemp 480	CharpyTemp 880
Maximum Low Temp.	°C	-80	-80
Temp. Control Range	°C	-80 to 30	-80 to 30
Temp. Control Stability	°C	± 0.1	± 0.1
Temp. Indication Display	°C	0.1	0.1
Compressor		2 at ¼ hp	2 at ¼ hp
Bath Volume	l	4	8
Magnetic Stirrer		included	included
Width	in / cm	13 / 33	13 / 33
Depth	in / cm	25.5 / 64.8	25.5 / 64.8
Height	in / cm	19 / 48.3	19 / 48.3
Weight	lbs / kg	96 / 43.1	100 / 45.4
Chamber Diameter	in / cm	6.5 / 16.5	7.75 / 19.7
Chamber Depth	in / cm	7.25 / 18.4	9 / 22.9
Height to Work Surface Above Bench Top	in / cm	13.5 / 34.3	13.5 / 34.3

#### Key Features

- Mechanically refrigerated.
- Temperature range of -80 to 30°C
- Available in 4 litre and 8 litre bath.
- Built-in magnetic stirrer and vortex breaker.
- Exceeds ASTM-E23 temperature stability requirements.
- Temperature controller

#### Key Benefits

- Eliminates costs and hazards associated with
- Expendable refrigerants.
- Test different materials as a wide range of temperatures
- Specimen capacities of 65 or 91.
- Stirrer and vortex breaker insure isothermal bath conditions.
- Liquid medium enhances temperature stability and
- Uniformity
- Accurate temperature control with temperature indication.

Heat Removal		CharpyTemp 480	CharpyTemp 880
20 °C	watts, Btu/hr	330, 1126	330, 1126
0 °C	watts, Btu/hr	350, 1195	350, 1195
-20 °C	watts, Btu/hr	300, 1023	300, 1023
-40 °C	watts, Btu/hr	280, 956	280, 956
-60 °C	watts, Btu/hr	250, 853	250, 853
-80 °C	watts, Btu/hr	60, 205	60, 205

Electrical Requirements		CharpyTemp 480	CharpyTemp 880
60 Hz Option	VAC, Amps	120, 9	120, 12
50 Hz Option	VAC, Amps	220, 6	220, 6

#### Charpy Racks

Description: Facilitate the transfer of specimens to testing machine

CharpyTemp 480	CharpyTemp 880
For 4L chamber, hold 65 specimens	For 8L chamber, hold 91 specimens

#### Fluid Selections

For best stirring results, choose a fluid medium with kinematic viscosity of 20 centistokes or less over the full operating temperature range.



## Sample Pre - conditioning chambers Series HO

**This apparatus is meant for impact tests to be carried out at low temperatures.**

It is made from double chambered stainless steel with isolating cavity wall from foamed polyurethane 65 mm thick. Complete with double chambered cover and specimen rack.

### Accessories

#### Dry-Ice Maker Typ H050

This device instantaneously produces the quantity of dry ice (solid CO<sub>2</sub>) required to reach temperatures down to -80 °C. The dry-ice maker must be connected to a liquid CO<sub>2</sub> bottle with connecting pipe and it produces 100g dry-ice tablets, having Ø 75 mm and 25 mm thickness. Weight: 3 kg

#### Pliers Type H054

special-shaped, pliers to take cooled specimens from the bath and place them directly into the Impact Tester.

#### Thermometer Type HD 9218

for the measuring of the bath temperature of test bars for impact tests, digital display with scale from -200 to +1372°C

#### Feeler Type HD 9218.1

for thermometer to read temperatures from -200 to +800°C.



Technical Data	H052	H052.1
Internal Width	125 mm	335 mm
Internal Depth	125 mm	235 mm
Internal Height	180 mm	210 mm
Weight	12 kg	15 kg

## Sample Pre - Conditioning Chambers Series EC

**With Digital Controller, Air - Cooled Version**

**This refrigerated circulator is equipped with a bath opening for direct temperature controlling samples.**

Construction: The inner chamber is constructed from stainless steel with a perforated specimen shelf to maintain good temperature uniformity. High efficiency, ceramic fibre insulation packed around the inner chamber. The outer case is constructed from mild steel with a durable grey finish. Door: The door is left hand hinged. A safety interlock switch operated by the door hinge cuts power to the heating elements and the fan if the door is opened during operation. Heating: Via a mineral insulated element located next to the fan at the rear of the chamber. The convected air is channelled using a baffle plate to the top and bottom of the chamber and returned through the centre of the baffle

plate. Cooling: Cooled via a LN<sub>2</sub> cooling package at the rear of the chamber with injector pipes running along the back on the shelves. Control: The control system is based on a Eurotherm 2408 CG self-tuning digital controller, enabling one programme of up to eight segments to be stored. Controls are positioned to the right. Cooling: Cooled via a LN<sub>2</sub> cooling package at the rear of the chamber with injector pipes running along the back on the shelves.



Technical Data	EC 2001	EC 2001.1
Working Temperature Range	-70°C up to 250°C	-150°C up to 350°C
Dimensions Overall	425 x 480 x 625 mm	425 x 480 x 625 mm
Dimensions Inside	300 x 300 x 300 mm	300 x 300 x 300 mm
Power Supply	230 V, 50 / 60 Hz	230 V, 50 / 60 Hz

## Broaching Machines Series BRM and BRM - M

**Designed for cutting Charpy V and U notches and Izod V notches in 10 mm square alloy steel specimens.**

**Available as manual or motorized models.**



Intended for bench mounting, this robustly constructed machines cuts the notches by means of a specially designed multi-toothed broach which is drawn across the specimen by rotating the spoked hand wheel for Series BRM - M manual models or by pressing down button at the motorized Series BRM models. A hand vice for holding the specimen is built onto the machine body and the tooling includes the adjusters and stops necessary to ensure notch depth and position are correctly set. Attachments are available to facilitate most common specimens. Broaches are not included and must be ordered separately from the range available. An operational floor-to-floor time of 17 secs. can be expected, although if a continuous heavy workload is envisaged we would strongly recommend our motorised machine.



### Available Broaches

- ISO-V 2 mm, Length 360 mm (Standard Broach)
- ISO-V 2 mm, Length 240 mm
- ISO-U 5 mm, Length 360 mm (Standard Broach)
- DVM KCU 3 mm, Length 360 mm
- DVMK KU 2 mm, Length 360 mm

## Charpy Sample Notching Machines Hand-Operated Notch Cutting Machine

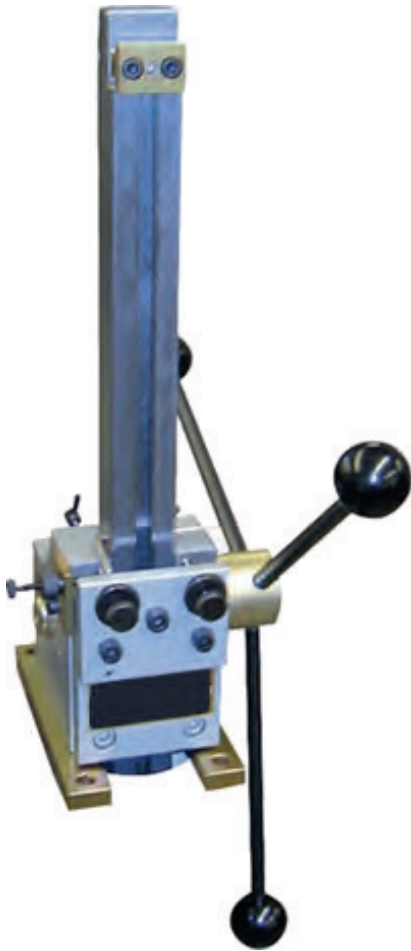

The Model 35 Hand Operated Charpy Notch Broaching Machine is designed for test houses and laboratories, which are producing small batches of test pieces in carbon steels, easily machined low alloy steels, non-ferrous and plastic materials.

The machine is of robust construction designed to be mounted on a customer's bench. This hand Charpy machine will cut Charpy and Izod 'V' and 'U' notches in pre-machined standard 10 mm square, sub-size and 0.45" diameter specimens.

Hand operation makes it ideal for small batch quantities.

The sample is secured in the machine by two clamp screws.

A light coating of cutting oil (RTD recommended) is applied to the broach & then the hand wheel is operated which draws the broach through the specimen to produce an accurate notch profile. After the notch has been cut, the sample is removed, the broach raised and the broach teeth cleaned, ready for the next sample.

The hand machine clamping device facilitates cutting of single notches in standard square, round and rectangular sub-size specimens.

The use of an optional multi-notch attachment allows cutting of multiple notches to be produced.

Once the adjusting screws have been set, a cycle time of 40 seconds per sample can be expected.

### Broaches

Broaches can be supplied for standard BS, ISO, EN, ASTM and other International Standard notch profiles. Due to the variety of broaches and notch configurations, broaches are ordered separately.

Due to the variety of broaches and notch configurations, broaches are ordered separately. All broaches, which have a unique serial number, are tested to ensure that they cut the correct form before despatch and a Certificate of Conformance is issued with each broach.

Special notch profile broaches may be supplied to order, send details for consideration. For broach quotation, please specify:

- Notch type
- Depth of notch
- Applicable Standard
- Material specification/Hardness Rc

Broaches for use on materials up to 42 Rc:

**Standard Broaches** – Our standard broaches are designed for use on carbon steels up to 42 Rc.

### Hard Cut Coated Broaches

This is a superior broach to the standard broach and is recommended for use on our Variable Speed Machine for tougher, harder & stainless steel materials to extend tool life.

If used on our Hand Machine, tool life is dependant on a smooth cutting action by the operator & the machining difficulty of the material.

Broaches	Standard	Hard Cut
"C" Type 2 mm deep "V" notch	30-027A2	30-027A2-H
"H" Type 3.3 mm deep "V" notch - for use on round samples	30-002A2	30-002A2-H
"N" Type 2 & 3 mm deep "U" notch	30-005A2	30-005A2-H
"JS" Type 5 mm deep "U" notch	30-004A2	30-004A2-H

### Broach Regrind Service

We also offer a broach regrind service. Please note this is dependant upon the condition of the broach. We only grind the land (cutting edge) and not the form. Generally if the form is worn or more than one tooth adjacent to another are broken then it may not be practicable to re-sharpen the broach.

## Motorized Notch Cutting Machines Model 31 & 34



**Motorized Charpy Broaching Machine** is a self-contained floor mounted unit, specially designed for cutting Charpy and Izod 'V' and 'U' notches in pre-machined standard 10mm square, sub-size and 0.45" diameter specimens.

The machines are available as **Fixed Speed Machine (Model 31)** and **Variable Speed Machine (Model 34)**.

The **Fixed Speed Machine** produces a consistent notch of superior quality to that produced by use of the milling process.

For a wider range of materials, the use of the **Variable Speed Machine** is recommended.

### **Machine Design:**

The machine is simple to operate and of robust construction, with large removable panels to provide access for routine maintenance. The design of the machine provides a comfortable working height. The cutting operation is achieved by drawing a specially designed multi-toothed broach across the specimen. The broach is drawn into the machine by precision twin lead screws via a geared mechanism to ensure the broach cuts perpendicular to the specimen clamp, limit switches are fitted for end of stroke travel. The lead screws are matched with the travel nut to ensure minimum operating clearances, while spring loaded safety guards ensure swarf and debris cannot enter into the lead screws and nuts.

### **Guards:**

The machine guards totally enclose the drive motor and operating mechanism. A broach guard is fitted to comply with safety regulations; limit switches prevent motor operation when the guards are open.

### **Method of Operation:**

A hand-operated clamp is mounted on the machine top plate at a comfortable working height and ensures that the specimen is held accurately and securely in position. It is fitted with adjusting screws and an end stop to ensure correct specimen positioning. A micro-adjustor provides manual adjustment for broach depth of cut and hence the final notch depth. Once set, the adjusting screws provide repeatability for the next specimen. The clamp can accommodate 10 mm square & 10 mm x 7.5/6.7 mm rectangular sub-size samples. For 10 mm x 5.0/2.5 mm rectangular sub-size samples a broach keep "W" is required and for circular specimens a different clamp block is required. The broach can easily be removed for re-sharpening or replaced to cut a different type of notch. The sample is secured in the machine by the clamp. A light coating of cutting oil (RTD recommended) is applied to the broach and the lower push-button/switch is operated which draws the broach through the specimen to produce an accurate notch profile. After the notch has been cut, the sample is removed, the broach raise push-button/switch operated, which raises the broach and the broach teeth are cleaned, ready for the next sample.

### **Multi-notch Attachment:**

There are 2 options for multi-notch samples.  
A) 0.45" diameter and 10 mm square sample attachment.  
B) 10 mm square sample attachment only.

The multi-notch attachment allows for single and multiple notches to be produced in 10 mm square and/or 0.45" diameter specimens. This option is normally fitted in our factory; it may be fitted at our customer's works providing they have access to a fitter & a surface grinder or milling machine.



# w+b Materials Testing Systems

## Size:

440 x 320 x 1020 mm  
Height to clamp handle  
440 x 320 x 1370 mm  
Height over broach guard

## Weight:

Fixed Machine 92 kg  
Variable Machine 95 kg

## Mounting:

Floor mounted using 4 x 10 mm diameter anchor bolts is recommended to ensure machine stability. Anchor bolts are not supplied.

## Electrical Supply:

Item 31 Fixed Machine -  
220-240 Vac, 1 phase  
50/60 Hz, 0.5 KVA

Item 34 Variable Machine -  
220-240 Vac, 1 phase  
50/60 Hz, 1.0 KVA

## Broach cutting speed:

Fixed Machine: 27 mm/s

## Variable Machine: Infinitely variable

7.1 to 37.8 mm/s

## Production Rate:

Fixed Machine:

The time for the broach travel in each direction is 10 seconds. So allowing for loading/unloading & cleaning of the broach teeth an operational floor-to-floor time of 40 seconds can be achieved.

Variable Machine:

The time for the broach travel in the cut direction is between 7 & 37 seconds and the return time is 10 seconds. So allowing for loading/unloading & cleaning of the broach teeth an operational floor-to-floor time of 40 to 60 seconds can be achieved, which is dependant upon the sample material & speed the broach is set to cut

## Accessories

Broach Keep 20-004A2 "W", for 10mm x 5.0/2.5 sub-size samples.  
Clamp Block 20-009A3 & Clamp Pins 22-002A4, for round samples.

Multi-notch attachments :

- A) 0.45" diameter and 10 mm square multi notch attachment 32-003A1
- or
- B) 10mm square multi notch attachment 21-006A1

Standard Broaches  
Special Broaches  
Notch depth caliper go/no go gauges

## Model 31 Fixed Speed Motorized notch cutting machine Model 31

Notches can be cut in carbon steels, easily machined low alloy steels, non-ferrous and plastic materials.

## Fixed Speed Drive:

Once the notch depth has been set and the specimen clamped in position, the machine operation is activated via lower and raise push- buttons. An additional stop button is fitted for emergency use.

The machine operation is controlled by the lower and raise push- buttons, which forward and reverse the machine motor, resulting in the broach cutting and return strokes being at a fixed speed. The motor has thermal overload protection to protect the drive mechanism.

**BROACHES** are ordered separately.

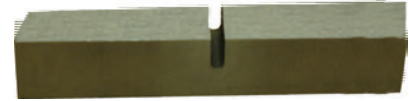

## Variable Speed Motorized notch cutting machine Model 34

The variable speed control allows adjustment of the broach cutting speed, so more difficult materials can be broached and to give extended broach life between sharpening.

Notches can be cut in carbon steels, more difficult to machine alloy steels, stainless steels, non-ferrous and plastic materials. The variable speed drive and our hard cut broaches allow a wider range of materials to be cut, including stainless steel or more difficult to machine alloy steels.

### Variable Speed Drive:

Once the notch depth has been set and the specimen clamped in position, the machine operation is activated via a lower and raise switch. A graduated knob controls the speed the broach cuts and the broach return speed is factory set at a constant fast speed. A stop button is fitted for emergency use.

The motor is controlled via a variable speed, frequency converter thyristor drive and the pre-programmed P.L.C. ensures motor overload does not occur to protect the drive mechanism

**BROACHES** are ordered separately.

### Multi-notch attachment:

The standard front plate can be replaced by a special multi-notch attachment, which allows single and multiple notches to be produced in 10mm square and 0.45" diameter specimens.

### Broaches:

Broaches can be supplied for standards BS, ISO, EN, ASTM and other International Standard notch profiles.

Due to the variety of broaches and notch configurations, broaches are ordered separately.

Special notch profile broaches may be supplied to order, send details for consideration.

For broach quotation, please specify:

Notch type

Depth of notch

Applicable Standard

Material specification/ hardness Rc

### Broaches:

Broaches can be supplied for standard BS, ISO, EN, ASTM and other International Standard notch profiles. Due to the variety of broaches and notch configurations, broaches are ordered separately.

Due to the variety of broaches and notch configurations, broaches are ordered separately.

All broaches, which have a unique serial number, are tested to ensure that they cut the correct form before despatch and a Certificate of Conformance is issued with each broach.

Special notch profile broaches may be supplied to order, send details for consideration.

For broach quotation, please specify:

Notch type

Depth of notch

Applicable Standard

Material specification/Hardness Rc

## Available Standard Broaches (V-notch 2 mm, 3.3 mm / U-notch 2 mm, 3 mm, 5 mm)

Broaches for use on materials up to 42 Rc:

Standard Broaches – Our standard broaches are designed for use on carbon steels up to 42 Rc.

### Hard Cut Coated Broaches

This is a superior broach to the standard broach and is recommended for use on our Variable Speed Machine for tougher, harder & stainless steel materials to extend tool life.

If used on our Hand Machine, tool life is dependant on a smooth cutting action by the operator & the machining difficulty of the material.

### Broach Regrind Service

We also offer a broach regrind service. Please note this is dependant upon the condition of the broach. We only grind the land (cutting edge) and not the form. Generally if the form is worn or more than one tooth adjacent to another are broken then it may not be practicable to re-sharpen the broach.

### Further Accessories:

Notch Depth Caliper Gauges with Certificate

Specimen Size Caliper Gauges with Certificate

## Charpy Sample Milling Machines Series CNM

**Charpy Sample Milling Machine is specially designed to allow laboratories and test houses to produce their own standard and sub-size Charpy / Izod test pieces ready for cutting the appropriate notch. Two variations of the Charpy Specimen Milling Machine are available to cover a wide range of materials.**

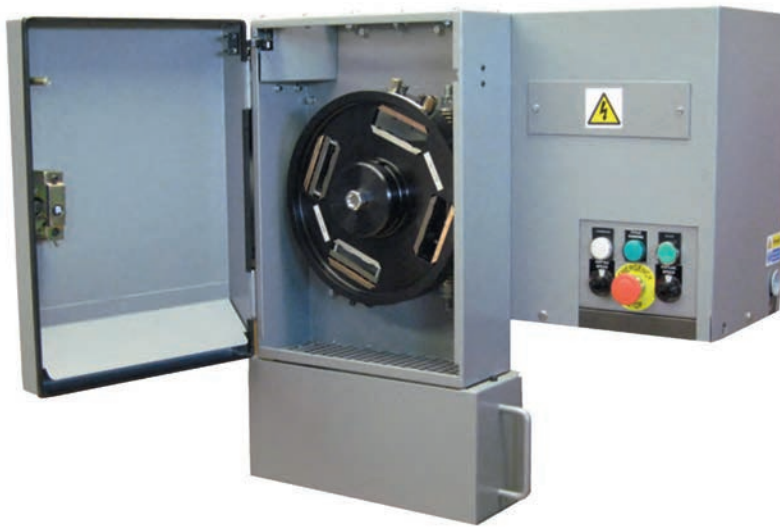

### Machine Description

The machines are of robust design and construction, enabling them to produce specimens to the surface finish and tolerances required by International Standards.

Both machines are designed for mounting onto a customer's bench and are fitted with an easily removable swarf (cuttings) tray.

The cutting process is carried out without cutting fluids.

A fully encapsulating removable cover allows ready access to the motor and drive for periodic maintenance.

### Work Holding Fixture:

The circular fixture allows up to four specimens to be machined during the same operation.

Various clamps, anvils and clamping screws are available to suit the type of rough cut blanks being used.

One circular fixture is included with each machine. For maximum machine production a 2nd fixture (optional extra) is recommended, so that whilst the 1st fixture is being machined, the 2nd fixture can have its samples loaded.

### Cutter:

The cutter is fitted with five ISO carbide inserts, which are easily replaceable. A micro adjuster allow for accurate control of specimen size and allows for compensation of cutter tip wear.

### Method of Operation:

The rotating work holding fixture is fitted with clamps, anvils and clamping screws to suit the type of blank being used, i.e. rough sawn square/ rectangular, round or tubular section and the size of specimen to be produced, i.e. 10 mm square or sub-size.

For ease of fitting samples, the fixture is removed from the machine and placed onto a bench mounted holding bracket, one bracket is supplied with each fixture.

Up to four rough cut samples may be loaded into the fixture, which is then re-mounted onto the machine spindle and the cutting cycle started. The machine cuts the first side of the samples (1st cut).

The fixture is then removed from the machine, turned through 180 degree and refitted to cut the second side of the samples (2nd cut).

After completion of the 2nd cut, the fixture is removed from the machine and placed onto the bench mounted holding bracket.

The samples are removed and remounted into the fixture at 90 degrees.

The fixture is then mounted into the machine to cut the third side (3rd cut). The fixture is then rotated to cut the fourth side (4th cut), which completes the production of the 10 mm square samples.

Adjustment of the micro-adjuster may be necessary to achieve the required size and dimensional accuracy of the finish machined specimen.



### 10 mm Square Specimens:

16 mm maximum square rough sawn and 18 mm maximum diameter section blanks can be used, to produce 10 mm square specimens to International Specification Standards.

The fixture pocket configuration:

A machine with 1 fixture; 2 pockets with 1st & 2nd cut clamps & 2 pockets with 3rd & 4th cut clamps.  
A machine with 2 fixtures; 1st fixture, 4 pockets with 1st & 2nd cut clamps. 2nd fixture, 4 pockets with 3rd & 4th cut clamps.

The customer to advise if round or tube section samples are to be used in 1st & 2nd cut pockets, as "V" serrated anvils will be required.

Customers can order fixtures, with any pocket configuration to suit their requirements

### Sub-size Specimens:

Sub-size specimens can be machined using a work holding fixture with special factory fit-ted cartridges. The 10 mm dimension is produced on a standard fixture, using 1st & 2nd cut clamps. The 3rd & 4th cuts are machined on a sub-size fixture, which is set at our factory to produce the thinner sub-size thickness



### The fixture pocket configuration:

Sub-size 7.5 mm thick; 2 cartridges set to 8.75 mm (3rd cut) & 2 cartridges set to 7.5 mm (4th cut).

Sub-size 5.0 mm thick; 2 cartridges set to 6.25 mm (3rd cut) & 2 cartridges set to 5.0 mm (4th cut).

Sub-sizes 7.5 & 5.0 mm thick; 1 cartridge set to 8.75 mm (3rd cut), 1 cartridge set to 7.5 mm (4th cut), 1 cartridge set to 6.25 mm (3rd cut) & 1 cartridges set to 5.0 mm (4th cut). Customers can order fixtures, with any pocket configuration to suit their requirements.

### Accessories

Additional rotating fixtures complete with clamps, anvils, clamping screws and a bench mounted holding bracket. The customer to advise pocket configuration.

Sub-size specimen fixtures and a bench mounted holding bracket. The customer to advise the sub-sizes required, for the fixture to be set at our works.

ISO replaceable inserts.

Specimen size go/no go gauges

## Model 158 Fixed Speed Milling Machine

The Fixed Speed Machine is recommended for customers who are producing specimens in carbon steels, easily machined low alloy steels, non-ferrous and plastic materials. This machine has a fixed cutter speed of 1.98 m/sec and a variable feed rate for the samples of 2.5-9.0 mm/sec. For customers producing specimens in a wider range of materials, see item 140 with variable cutter speed.

### Fixed Speed Machine

Using two work holding fixtures, 4 machined specimens can be produced every 20 minutes with the feed rate set in a mid-position. The mid position is a typical setting for general carbon steels.

### Scope of supply includes:

- Fix Speed Charpy Milling Machine
- One work holding fixture
- One set of tooling

## Model 140 Variable Speed Milling Machine

The Variable Speed Machine is recommended for customers who are producing specimens in carbon steels, more difficult to machine alloy steels, stainless steels, non-ferrous and plastic materials.

This machine has a variable cutter speed of 1.0-2.5 m/sec and a variable feed rate for the samples of 2.2-9.0 mm/sec.

The varying of the cutter speed for differing materials improves the cutter tip life

### Variable Machine

No specific production rate can be quoted for the variable speed machine due to the variation in machine feed & speed settings, which are dependent upon the sample material.

### Scope of supply includes:

- Variable Speed Charpy Milling Machine
- One work holding fixture
- One set of tooling





*walter+bai*

**walter + bai ag  
Testing Machines**

Industriestrasse 4  
8224 Löhningen · Switzerland

Tel. +41 (0)52 687 25 25

Fax +41 (0)52 687 25 20

info@walterbai.com · www.walterbai.com

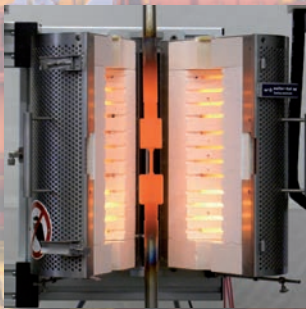

- Static Universal Testing Machines, Electromechanically or Servohydraulically driven
- Dynamic Multipurpose Testing Systems for Advanced Material and Component Testing
- Torsion, Rotary Bending, Impact Pendulum Testing Machines
- Hydrostatic Pressure Testing Systems
- Customer Specific Testing Machines, Modernisation of Existing Testing Machines

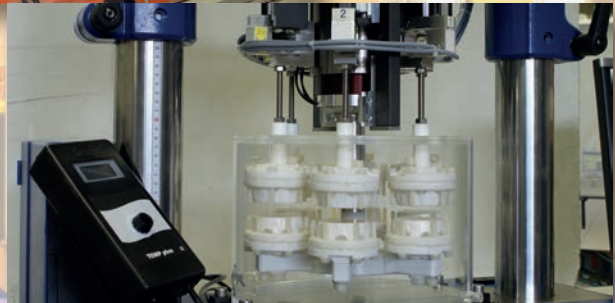
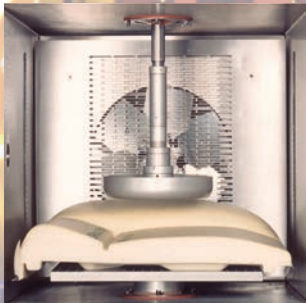

- Accessories for Material Testing, incl. Digital Controllers, Application Software, Hydraulic Power Supply, Grips and Fixtures, Extensometers, Furnaces and Climatic Chambers, a.s.o.
- After-Sale Service at Customers Laboratory
- Calibration of Material Testing Machines