

## Servo-hydraulic Multipurpose Fatigue Test System Floor Standing with Actuator in lower base Series LFV up to 630 kN

These Test systems meet the full spectrum of dynamic, fatigue and monotonic applications including TMF (Thermo-Mechanical Fatigue), LCF (Low-Cycle Fatigue), Fracture Mechanics, HCF (High-Cycle Fatigue), High-Strain Rate and Component Testing.

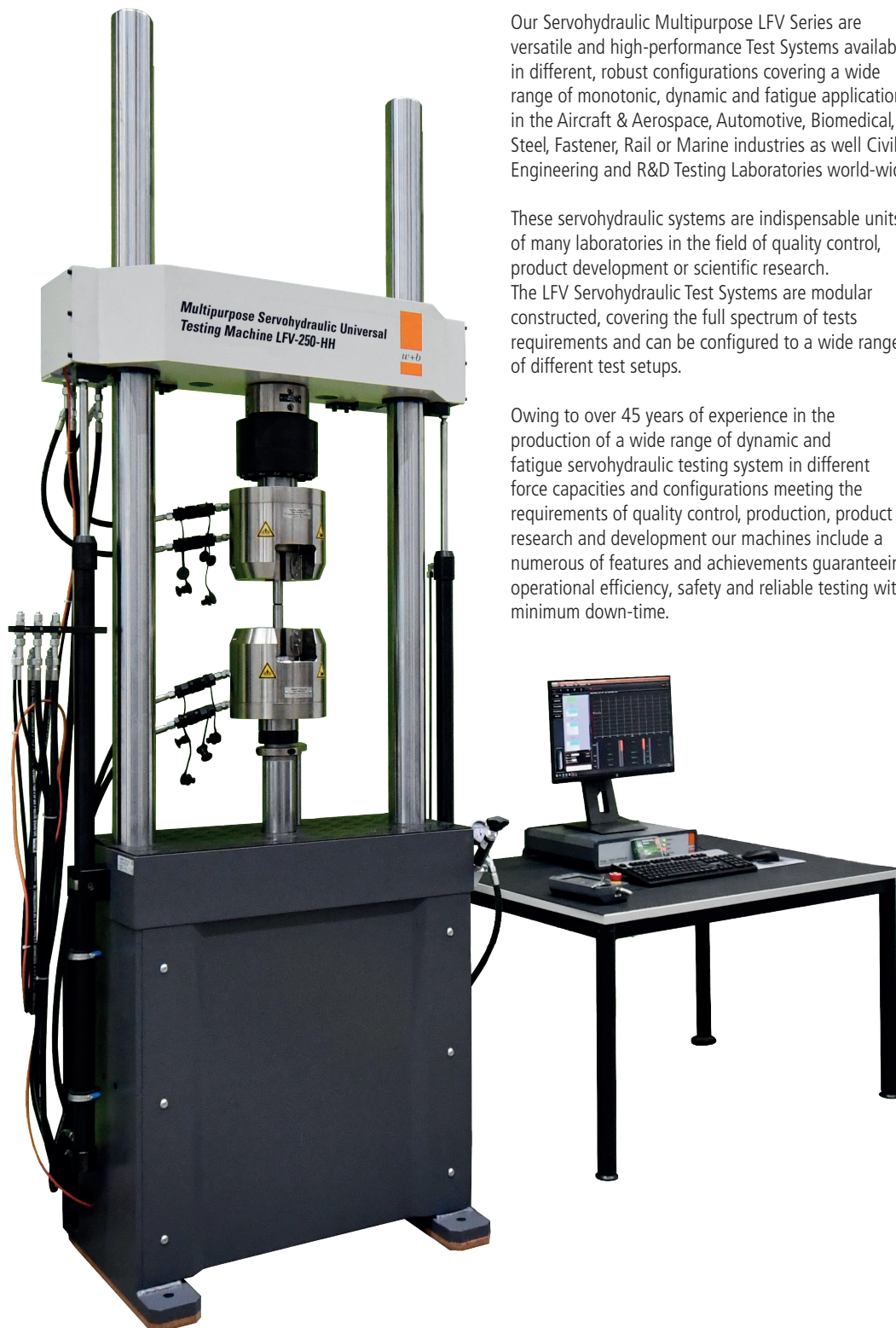

Our Servo-hydraulic Multipurpose LFV Series are versatile and high-performance Test Systems available in different, robust configurations covering a wide range of monotonic, dynamic and fatigue applications in the Aircraft & Aerospace, Automotive, Biomedical, Steel, Fastener, Rail or Marine industries as well Civil Engineering and R&D Testing Laboratories world-wide.

These servo-hydraulic systems are indispensable units of many laboratories in the field of quality control, product development or scientific research. The LFV Servo-hydraulic Test Systems are modular constructed, covering the full spectrum of tests requirements and can be configured to a wide range of different test setups.

Owing to over 45 years of experience in the production of a wide range of dynamic and fatigue servo-hydraulic testing system in different force capacities and configurations meeting the requirements of quality control, production, product research and development our machines include a numerous of features and achievements guaranteeing operational efficiency, safety and reliable testing with minimum down-time.

# w+b Materials Testing Systems

All LFV servohydraulic systems integrates reliable w+b servo-controlled hydraulic actuation with high-resolution & high-speed digital closed loop controls, a broad portfolio of complement accessories and comprehensive Dion7 application software packages making these systems the suitable across the full spectrum of static and dynamic testing including:

- Tension
- Bending
- High Cycle Fatigue
- Fracture Toughness
- Crack Propagation
- Environmental Testing
- Component Durability
- Compression
- Thermo Mechanical Fatigue (TMF)
- Low Cycle Fatigue (LCF)
- Fatigue Crack Growth
- K1C / J1C
- Stress and Strain Relaxation
- Component Strength

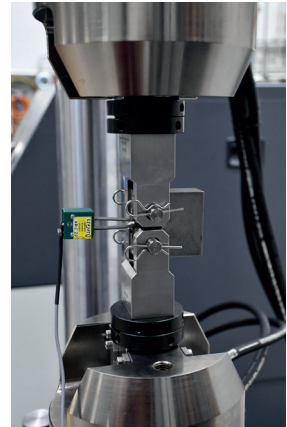

## Versatile and Highly Configurable Load Frame Design

Our servohydraulic test systems are developed to a high degree and cover a wide variety of fatigue testing for various modes of loading and test specimen configuration. Our proven, technically advanced load frames, actuators, hydraulic components and sensorics have evolved through use in the field over decades.

The modular design offers options such as crosshead clamping and movement options, hydrostatic actuator bearings with selectable servovalve options to acceleration compensated transducers.



## Freestanding

These test systems are freestanding and normally installed without special foundations.

## High Stiffness / High efficiency

Our load frames are designed with high axial and lateral stiffness. Increased load frame stiffness means higher efficiency as the amount of energy needed to overcome the frame deformation is low and the bulk of the displacement will be absorbed by the specimen. To increase the stiffness low deformed crosshead and base platen and generous selected columns for increased stiffness is included. This results in increased load frame weights which improves the natural frequency of the load frame and reduces vibration introduced into laboratory floor / building.

**The Columns** are precision-machined, inductive hardened, inductive hardened, polished and hard chromium-plated.

Hardened surface: avoids any indentation while the crosshead is clamped.

Polished execution: accurate straightness of the column allows the parallel height adjustment.

Hard chromium-plated column: reduces corrosion of the column and ease cleaning. The column must not be lubricated with oil.

## Excellent Alignment

Precise machined load frame parts, accurately assembled and aligned and high stiffness assures that the loading train with the testing machine have excellent alignment of the load line with the specimen to prevent premature specimen warping or buckling under high loads.

## Accessible and Ergonomically Workspace

Another key attribute of our loading frames is to provide accessible space for installing and removing test specimens, grips or fixtures and other test accessories in an ergonomic way and position.

If your test needs require a bespoke workspace design our in-house design team will design and build the frame, fixtures, and accessories so that it will meet your requirements in the best possible way.

## Convenient Test Space Adjustment

These test system offers convenient hydraulic crosshead positioning to accommodate the suitable workspace. The upper crosshead is locked to the column by a passive clamping system that offers safe clamping without any hydraulic pressure applied. It guarantees highest operating safety as compared with systems using hydraulic pressure to clamp the clamping force will not drop if any leakage appears on the clamping cylinders. The passive clamping system will only be pressurized to unclamp and during the height adjustment.

The crosshead positioning control is done through the handset minimizing human interfaces. The handset control lets you operate the crosshead lifts, locks, and grips to assist in specimen installation procedures. The handset also contains the emergency stop switch and the actuator rod speed control.

Depending on your demands these test systems are alternatively available with manual crosshead lock & positioning or manual lock and hydraulic positioning.

Version -M: Manual crosshead lock and positioning

Version -HM: With manual crosshead lock and hydraulic height positioning.

## Latest Drive Technology

The LfV Test Systems are closed loop controlled through the latest high-resolution, high-speed digital control system PCS8000. The PCS8000 ultra-high-speed closed loop control and data acquisition rate on all channels combined with 24-bit high resolution transducer conditioning rate is achieved by a 64-bit processor running at 1 GHz.



## Advanced Closed-Loop Control

As control channel available are any connected inputs as well as virtual (calculated) channels that might open many new opportunities to your application. The versatile concept of the PCS8000 is based on latest technology and supports applications with virtually no limits.

## Expandable

Testing Machines powered by two-channel PCS8000 you will be ready for your test demands of today & tomorrow. The test systems can be equipped with up to 26 amplifier cards for control or data-acquisition and up to 20 virtual channels operating at full rate. All physical and virtual channels can be used as data-acquisition as well as control channels. Additional 24 digital outputs and 16 digital inputs to control external devices are provided.

## Easy Test Set-Up Controls

The LfV Test Systems are available with centralized controls on the digital handset. The handset includes all functions from test set up until the test is running.

- Display of up to three (3) channels (example Force / Piston Stroke / Strain)
- Zeroing of control and measurement channels
- Crosshead unclamping and height positioning
- Piston or Crosshead Movement via trim function
- Adjustable piston or crosshead speed
- Opening and closing of hydraulic, pneumatic or motorized grips
- Display brightness adjustment
- Rotation of display
- Integrated Emergency STOP
- Key-Switch to activate the setting mode according to the new CE Machine directive for testing machines or actuators.



## Operator Safety

Our LFV series of test systems fully comply with the safety requirements of the EC Machinery Directive and are supplied with the related EC Declaration.

## Specimen & System Safety

Specimen Protect function prevents your specimen from being damaged during setup and gripping. The LFV Test Systems are protected against overload and provide the ability to set limits for load, piston stroke travel, strain or any other connected transducer preventing damage to your system, load cell and grip or fixtures.

## Machine Safety

Provides highest level of machine safety including overload protection of the frame, overload protection of the load cell, two-channel safety circuit according to the machinery directive.

## Configurable & Extendable

The modular design enables us to adapt these tests systems to virtually any of your requirements. Configure your test system to meet your unique needs of today and extend it in the future when your test needs would change.

## Seamlessly Integration of Accessories

The LFV series allows the seamlessly integration of a variety of grips and fixtures, extensometers, environmental simulation chambers and furnaces, different software packages and other accessories to suit your specific testing needs.





## Hydrostatic Pocket Bearings Actuator

Another quality feature of the w+b LFV Systems is the integrated double-acting, double-ended, equal-area servo actuator with real Hydrostatic Pocket Bearings in round (no tie rod) design.

These linear actuators with hydrostatic bearings enhance system reliability and provide the best friction-free static and dynamic performance, allows high side-loads and emergency running, and provides virtually unlimited service life. They represent the high-end solution with virtually service-free operation.

## Double Ended (Equal Piston Area) Construction:

Unlike single rod cylinders, the surfaces for extension and retraction in the actuator with a through piston rod, called double ended actuator, are of the same size. Especially in combination with symmetrical regulating valves, surfaces of the same size allow realizing higher dynamic frequencies as equal oil flows to both actuator chambers occur with positive effect to the control accuracy and accumulator function. Additionally, they feature higher side load resistance than single ended actuators but are about twice the length of the single ended actuators.

## Round Design:

Round head cylinder design have rotationally symmetric parts and thus can be produced (manufactured) very accurate and are space-saving and rigid (stable). Compared with the simple constructed tie rod cylinders which are equipped with long screws, so-called tie rods, which connect the two covers over the entire length of the cylinder the round design extend the actuators lifetime because of lower stress on the guides.

The simple tie rod construction requires uniform pre-stressing of all tie rods to prevent straining and deformation of the entire cylinder. The longer the cylinder, the more important this gets. Deformation due to incorrect mounting will reduce the cylinder's lifetime because of excess stress on the guides.

## Hydrostatic Pocket Bearings:

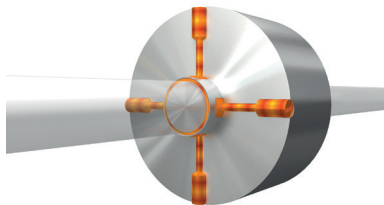

Servo Actuators with real hydrostatic bearings are used where highest dynamic response and control accuracy is required or radial force loading can appear. An important feature of these servo actuators is low friction as only the viscous friction of the oil in the seal clearance is present at the servo actuators piston. By optimising the installation space required for the seal (at zero pressure) between the bearing oil drain and the outside, the friction here is also kept extremely low within the tolerance range.

Hydrostatic bearings are supplied with system pressure independent of the relative movement between the piston rod and the bearing. Four (4) pockets are situated in the bearing bush. Each

pocket is bordered by a bearing land. When under pressure, fluid is continuously fed to the pockets. Fluid flows to the bearing ends via the clearance between the piston rod and the bearing lands. In a bearing under no load, the fluid pressure is about the same in all pockets. Hence the clearances at the bearing lands in the pockets are also about the same. The piston rod is centred in its mid position.

Once the bearing is under load, the piston rod is moved from its mid position in the direction of the load. Hence, the clearance in one pocket becomes larger and the resistance to the flow lower. The clearance in another pocket is forced to become smaller and the resistance to flow increases. If the flow to the individual pockets is kept more or less constant, the pressure will then increase in one pocket, whilst it decreases in the other pocket. As a result of this pressure difference the external loading is absorbed.

The material pairs for bearing and piston rod or piston and cylinder housing are carefully selected and proved through our long-term experience.

The clearance between piston rod and pocket bearings or between piston and housing is designed so that no metal-to-metal contact occurs.

The oil supply for the pocket bearings is provided from the hydraulic oil supply (hydraulic power pack).

## Actuator End Cushioning:

The actuator has integrated cushioning.

Cushioning of some sort is required to decelerate a cylinder's piston before it strikes the end cap. Reducing the piston velocity as it approaches the end cap lowers the stresses on cylinder components and reduces vibration transmitted to the machine structure.

## Sealing System functional oil seal

An especially low-friction functional oil seal is installed behind the functional oil port, which seals the rod from the inside. A wiper ring completes the system. Since in this system the seal is only pressurized with the functional oil pressure, the effect of the actuator's friction behaviour is negligible. Thus, this seal is subject to very little wear.

This special seal system does not require the installation of a suction pump to remove the leak-oil. The leak-oil port can simply be connected to the hydraulic power pack tank by suitable sized leak oil hose.

## Precision

The piston rod of a hydraulic cylinder moves in the cylinder tube and cover. Reliable functioning requires sufficient guide clearance between the component parts. The guide clearance must be sufficient to allow for the expansion of components parts caused by temperature differences during service. Too much clearance on the other hand would permit too much tilt. This would increase the stress on the guiding elements and thus the wear and tear of component parts. The perfect guide clearance for the hydraulic actuators is reached with ISO standard tolerance grade IT7 in combination with high degrees of roundness of piston rod and actuator tube as made possible by cross-hatching or honing.

## Cross-Hatching of Piston Rod

In hydraulic actuators, sealing elements kept the pressure (oil) inside the cylinder. In order to minimize the wear and tear on seals, the sliding surfaces, i.e. the surfaces must be treated accordingly. With a too fine and smooth surface, the lubricating film would break under the sealing lip, which would inevitably lead to incomplete lubrication and thus increase wear and tear on the seal. Too rough surfaces would increase wear and tear or sealing elements by abrasion. The perfect surface for piston rods and tubes in hydraulic actuators can be created by cross-hatching – a linear grinding movement superimposed on a circular one. This complex process on a piston rod – called cross-hatching – creates surface structures with 45-degree grinding marks which guarantee an uninterrupted lubrication film under the sealing lip. Advantages of Cross-Hatching of Piston Rod

- Best lubricating properties for the sealing elements
- No dry-running
- Little wear
- Low friction
- Long life time



## Internal Digital SSI Displacement Transducer

The actuator is equipped with coaxial integrated, digital SSI positional transducer as standard. Using this system, the actuators stroke (position) is measured and then fed as an actual signal via the measuring amplifier to the digital controller for position data acquisition or acquisition and control signal.

The digital displacement transducer provides noise free digital signal, better linearity compared to LVDT's and is insensitive against any disturbance.

**Piston anti-rotation system** for the actuator to prevent the natural tendency of the actuator to rotate. The anti-rotation system can be easily mounted and dismounted.

## Direct Actuator Porting

The direct mounting and porting of the servovalve manifold platen and the servo-valves minimizes pressure loss that would lower the system efficient.

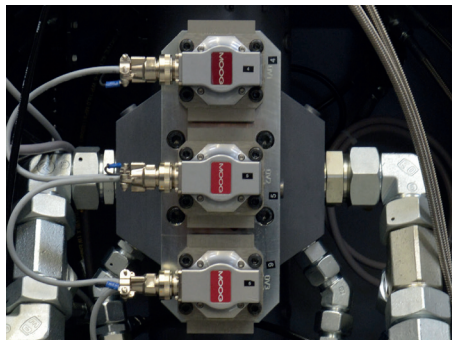

## Servo-valve manifold platen & Servo-valves

According to the dynamic performance requirements the machines are equipped with suitable servo-valve manifold platen and Servo-valves. The servo-valve unit is mounted direct on the axial and torsional actuators for the highest possible response and most accurate test control.

Commonly used Moog servo-valves are Series 761 (one (1) to four (4) valves), 791 or 792 valves which are suitable for electrohydraulic position, speed, pressure or force control systems with high dynamic response requirements.

If the machine will be used in a wide range of application from monotonic static testing over LCF up to HCF testing electric operated servo-valve manifold blocs are available. These platens are designed for more than one valve, commonly one valve with low-flow rate for static and quasi-static application with low oil-flow demand and valve(s) with larger flow-

rate for those application that requires higher oil-flow (example HCF Tests). The valve(s) with the larger oil-flow can be electrically deactivated in order only the valve with lower oil-flow is active. This electrically operated dual manifold-blocs are available for servo-valve combinations with Moog 761 series or combinations with high-flow Moog 791 or 792 series combined with Moog 761 series.

## Actuator Chamber Isolation Platen

When start-up or safety requirements make it necessary to isolate the servovalve from the actuator, the sandwich isolation platen can be installed (option) and triggered electrically.

Reaction time:  $\leq 0.1$  Second.

This module contains 2 pilot-to-open logic valves and a 3-way normally closed solenoid.

When either the solenoid is de-energised or there is a loss in supply pressure the logic valves isolate the servovalve control ports and thus lock the actuator in position.

## Crossport relief valve (CRV) and dual port relief valve (DRV)

Optional when required we are offering CRV or DRV manifolds for limiting high-pressure situations caused by rapid acceleration or deceleration of an inertial load.

- CRV's relieve one control port to the other
- DRV's relieve either control port to tank

## Adjustable metering orifice (AMO) manifolds

May be optionally used to add hydraulic damping for improved dynamic performance in a servosystem. The bypass orifice is incorporated into a manifold between the servovalve and the motion device. Can be adjusted to set the optimum performance after final installation.

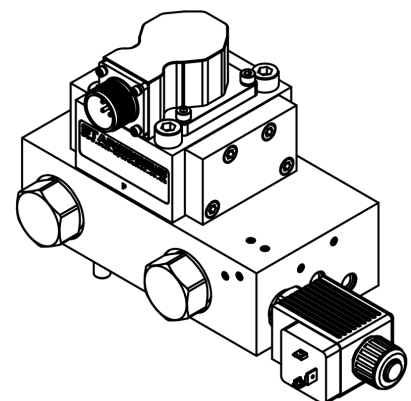

## Control Port Shut of Platen

This platen provides a convenient method of closing the output of a 4-way servo valve. In applications that use multiple servovalves on a single actuator it is possible to have unwanted offset at the main spool making for an inefficient setup. The platen provides the user a way to quickly isolate each of the valve's output and therefor allowing accurate nulling of any remaining valves connected to the actuator. Two indicators provide the user clear identification of the open or closed position.

## Flushing platen

Flushing platen employed in place of valve when initially cleaning hydraulic fluids

- Mount in place of the valve when filtering hydraulic fluid prior to use in the system
- Helps eliminate the possibility of servovalve contamination new system flushing or fluid replacement operations

## Close coupled accumulators

To minimize hydraulic pressure fluctuations are mounted direct on the servo-valve manifold direct at the actuator.

Processes with a high dynamic response require the use of membrane accumulators of sufficient size in the pressure and return lines in the direct vicinity of the servo valve.

The optimal size of the installed accumulators in the pressure and return line varies with the actuator and hydraulic power pack size.

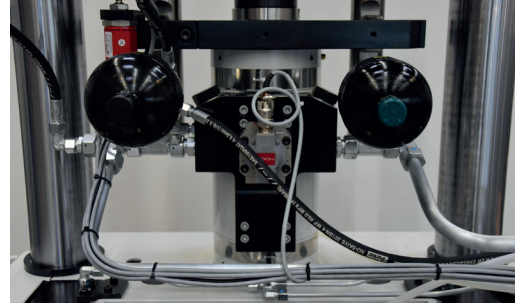

## Option for T-Slot Platen

These series of load frames are also available with additional T-slot platen that gives you a workbench for mounting and testing everything from a small material specimen to a large component, subassembly or finished goods or you can mount grips, fixtures, or any other working tool on it.



You can also extend your test system to multi-channel; multi-axis testing when adding an additional linear actuator or torque drive. This additional actuator you can mount in the same way as you can mount specimens or subassemblies direct onto the t-slot platen or via reaction bracket, adapter plate or support horizontally or with any inclination onto the T-slot platen.

The t-slotted base platen is supplied with longitudinally machined clamping type fixing T-slots. When required the platen can be supplied with guiding T-slots with H7/H8 tolerance, with transversal directed or crossed t-slots and with additional threaded holes and fitting holes.

The nickel-plated base platen that is corrosion resistant against air, water, most diluted acids, and bases and is easy and quick to clean is available on request.

## System Overview

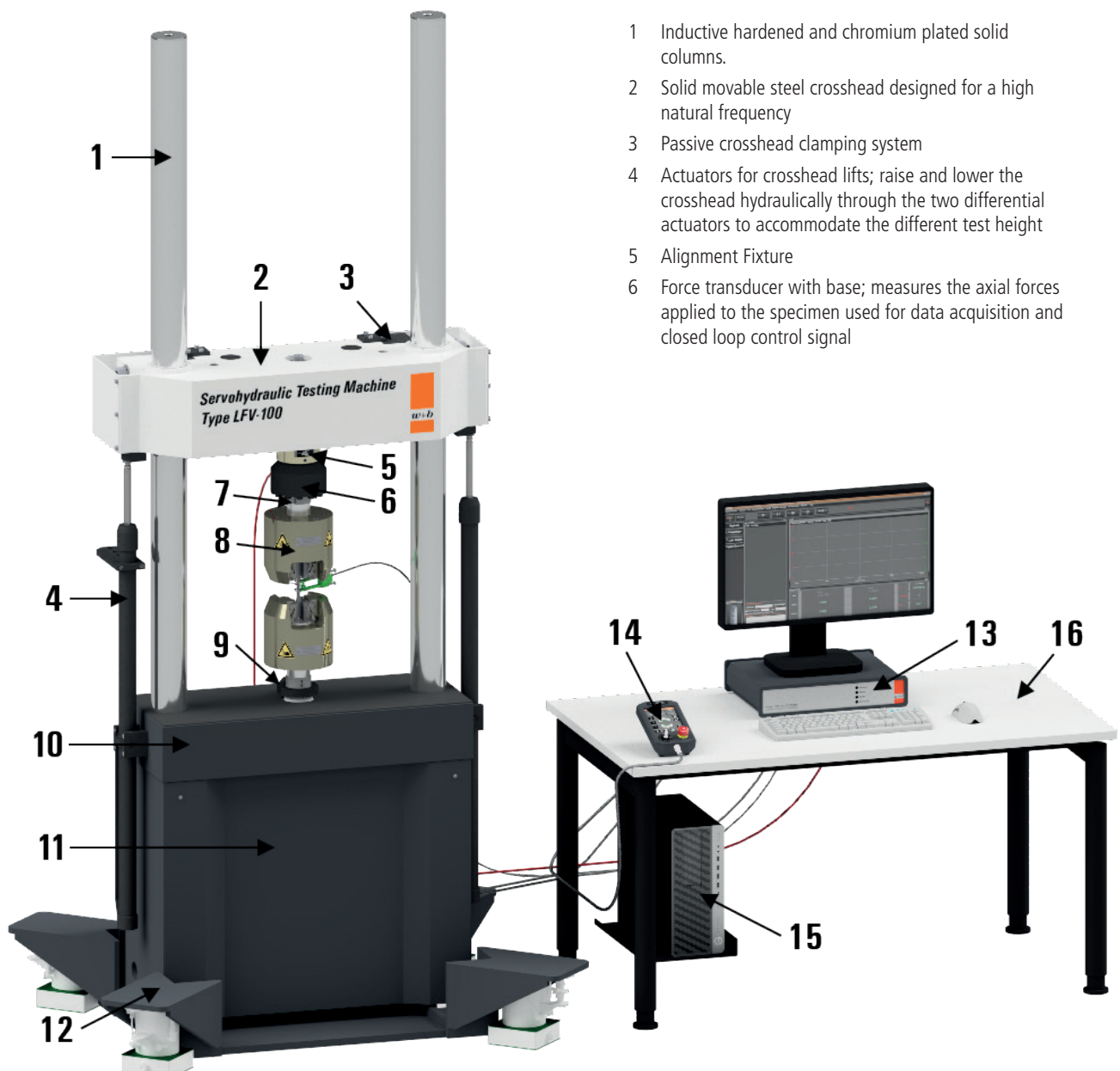

- 1 Inductive hardened and chromium plated solid columns.
- 2 Solid movable steel crosshead designed for a high natural frequency
- 3 Passive crosshead clamping system
- 4 Actuators for crosshead lifts; raise and lower the crosshead hydraulically through the two differential actuators to accommodate the different test height
- 5 Alignment Fixture
- 6 Force transducer with base; measures the axial forces applied to the specimen used for data acquisition and closed loop control signal

- 7 Dynamic connection (washer)
- 8 Grips & Fixtures
- 9 Removable anti-rotation device prevents the natural tendency of the actuator to rotate.
- 10 Solid base platen
- 11 Integrated hydraulic actuator with piston stroke transducer, servovalve(s) and closed coupled accumulators
- 12 Optionally active air damping system supplied with regulation system  
Standard: Isolator pads reduce transmission of vibrations.
- 13 Digital controller PCS8000
- 14 Handset: portable digital handset with emergency stop
- 15 Personal Computer with Dion7 application software
- 16 Working table (option)



## Force Train

The force train includes anything in the force's path including load frame, actuator, connecting bolt and washer, grip, specimen, load cell with its adapter and alignment fixture.

Our LFV test system are designed with short and stiff load train including actuator which is mounted in the base platen provides a short force train for increased stiffness and better side load capability.

An additional bronze flange on the upper surface of the base platen secures the actuator with emergency running when side loads appear that exceed actuators capacity.

## Alignment Fixture

It has been recognised for many years that bending stresses associated with misalignment between the load axis and the axis of the parallel length of the test piece can significantly influence the magnitude of the material property under investigation in mechanical tests.

Sources of misalignment include inaccurate machining of the test piece, poor conformance of the test piece centre line with top and bottom grip centre lines, poor alignment in the loading train, inadequate test machine alignment and insufficient test machine lateral stiffness. Combinations of these sources of misalignment occur to various degrees in any test, depending on test piece machining tolerances and on the configuration of the loading system.

Many international standards as ASTM E1012, ISO 23788, , NASM1312, MIL-STD-1312B or regulations like for example GE S-400 or GE S-450 refer to alignment issues or describe the practice for verification of test frame and specimen alignment under axial force applications. Furthermore Nadcap accreditation (audit criteria AC7101 & AC7122) define the verification of alignment based on ASTM E1012.



For applications where very accurate specimen alignment is required, including LCF, TMF , HCF and others, the fixture to align the specimen is used. In combination with this alignment fixture for material testing machines accurate and productive alignment adjustments during verification practice and while the load train is pre-loaded can be performed. Mounted mostly between the crosshead and the load cell the alignment fixture provides full concentricity and angularity adjustment. Alignments are not lost when small changes in alignment occur because the alignment fixture remains preloaded all the times. As the alignment fixture remains preloaded at all times, alignments are not lost when small changes in alignment occur as during preloading process.

The fixture is designed for use with the alignment verification accessories consisting of strain gauged specimen, electronics and software.

## High Precision Fatigue Rated, Low Profile Tension & Compression Load Cell

These LFV test systems are equipped with a fatigue rated high precision low profile tension & compression Load Cell with eccentric load compensation for static, quasistatic and dynamic / fatigue materials testing. Based on the shear web principle these accurate load cells offer low linearity and hysteresis errors for accurate materials testing. These low-profile sensors are rotationally symmetrical, flat and convince by their versatility. Through a special mechanical adjustment process this load cells are insensitive to parasitic loads. This force transducers offers high-stiffness and high natural frequency.

### Features:

- Temperature compensated strain gages
- High performance
- Eccentric load is compensated
- Very low temperature effect on output
- Low deflection
- High natural frequency
- Shunt calibration
- Barometric compensation
- Tension and compression
- Compact size

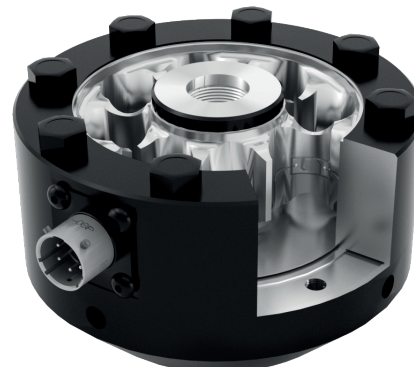

## Interface to Grips & Fixtures with Spiral Washer and Stud

The grips provide an internal thread that allows a backlash free connection of the grips to your testing machine with spiral washer and connector stud. The washer/stud connection provides backlash-free connection between the grip and the testing machine.

### Grips

These test systems are available with a variety of grips which can be selected according to your requirements. The most popular grips are:

- WGR non-shift Wedge Grips
- Collet Grips
- High Temperature HTG Grips

## Side-Loading Hydraulic Non-Shift Wedge Grips Series WGR-H

The hydraulic grips WGR-H Series are general-purpose grips for static, pseudo-static and dynamic (through-zero) testing which provides excellent sample grip on a variety of materials.

Their high lateral stiffness and constant lateral gripping force assure and maintaining excellent alignment. The WGR series is versatile, allowing the installation of inserts for flat and round specimen.

Each grip is hydraulically operated, with gripping force being applied via movement of the grip body relative to the wedge-shaped jaw faces. Thus, the wedge inserts remain stationary on the same vertical position when applying initial gripping force to sample while the body of the grip is moving.

This feature minimises the preload applied to the sample by the grips and minimize compressive force being applied prior to testing. The grip body wedge area is fitted with jaw guides, to ensure that the jaw faces remain square to each other and to the specimen. Each jaw face is located in the grip body by two extension springs, which allow the jaw faces to release the specimen after testing.

The open-front construction makes specimen insertion quick and easy. This translates into you spending less time inserting and aligning specimens and more time testing.

WGR series allows also the proper clamping of short specimens, minimizing material.

This hydraulic non-shift wedge grips are designed for a wide clamping range of round and flat specimens. The inserts come in a variety of surfaces and shapes to meet your requirements. Standard inserts do a good job of gripping materials such as steel a.s.o. Compression platens or bending / folding devices may be fixed directly into the grips.



## Hydraulic Collet Grips for Fatigue Testing of Round Specimens

The HCG Hydraulic Collet Grips are the best solution for fatigue testing of round smooth shank specimen. They are well suited for any kind of fatigue testing including LCF, TMF, force controlled constant amplitude axial fatigue test according to ASTM E446, ISO 1099 or EN 6072 and constant amplitude strain controlled axial fatigue tests according to ISO 12106, BS 7270 and others.

This hydraulically actuated grips hold a specimen during testing with a constant gripping force regardless of the applied axial test force. The short and stiff grip design minimize lateral movement and provides superb alignment and repeatability that minimize the introduced bending strain that can invalidate your test results.

These grips permit an easy sample loading into to collet inserts. The grips are accurate machined with main parts polished.

The amount of bending strain in the specimen is beside of the gripping methods also affected by the specimen design. Better alignment can be achieved using smooth ended specimen as threaded specimens generally give poorer alignment with equally poorer reproducibility. Further as there are no threads or button ends to be machined the specimen reparation is less expensive.

These grips can be mounted on hydraulic or non-hydraulic static testing machines and dynamic rated systems. Each grip has two hydraulic ports for the fluid, one for opening of the grip and one for closing / clamping. The hydraulic supply can be either from an existing hydraulic source or via stand-alone or in the machine integrated hydraulic pump and valve assembly.

In combination with extension rods and high-temperature hydraulic fluid the grips can be mounted in environmental chambers.

The grips are nickel plated, wear and corrosion resistant.

These Grips are produced up to 400 kN capacity. Built for years of trouble-free testing at its full rating!



### Key Features

- Providing constant, lateral gripping force
- Superior alignment
- Stiff and short construction
- Easy specimen loading
- Quick changing of collets
- Inexpensive specimen production



## Hydraulic Parallel Closing Dual-Side Grips Series SPG

This open-front constructed parallel grips with two side hydraulic clamping pistons deliver proven gripping performance for static to fatigue testing on a wide range of materials including steel plate, steel rods, machined specimens including rounds and flats, reinforced steel bars, 7-wire strands, and others.

The SPG Grips applies a defined clamping force that ensures optimum gripping for specimens including sensitive ones and assure repeatable test results.

Our hydraulic grips control provides constant gripping forces and together with our PCS electronics unwanted forces acting on the specimens are avoided through our mixed control mode during the gripping process that limits such unwanted forces. All our SPG Grips are supplied with integral synchronizing self-centring providing repeatable parallel closing and provides many advantages over simple hydraulic solutions like flow control valves that are sensitive to temperature, oil viscosity and dirt. Another big advantage of our synchronizing self-centring system is, that there is no need to open the grips completely to have a centred clamping of the next specimen.

### Key Features

- Two side hydraulic clamping system in horizontal clamp action
- Ultra-Precisely aligned
- Ensuring constant gripping forces and repeatable test results
- Improved design allows to grip also short specimens
- Rigid constructions require low clamping pressures minimizing pressure peaks at specimen failure and increase trouble free operating.
- Time saving as no need to open grip completely to maintain specimen alignment
- Avoiding the need of mechanical stroke limiters or else
- Open-front construction with symmetrical housing design for easy exchange of inserts, front loading of specimens, preventing ingress of scale and dust etc.
- Independent control of the upper and lower grip
- The desired clamping force can be easily pre-selected and is measured and displayed

## High Temperature Hydraulic LCF Grips

The HTG grips are the ideal choice for conducting high-temperature Low Cycle Fatigue (LCF) Tests in combination with high temperature furnace.

These grips with hydraulic specimen preload are specially designed for Low-Cycle Fatigue Testing or for any other reverse axial stress application up to 15 Hz or tension-only application.

The reverse rated grip extension with inside pushrod for specimen preloading and the exchangeable specimen adapters extend into the heated zone of the furnace. These parts are made of high-temperature super alloys with high strengths at high temperature.

The grip body, which remains outside of the furnace, is water cooled and isolate the hot parts of the grips from the actuator piston rod and from the load cell or other accessories.

When hydraulic pressure is applied the grip piston moves and push the pushrod against the end of the specimen. The adjustable grips pressure defines the specimen preloading that can be set in relation to expected introduced compressive forces.

These grips can accommodate various sizes of threaded and button-end specimens. A view port in the grip extension helps to position the threaded specimen in the adapters.

All parts of the HTG grips are accurate machined with tight tolerances for improved and repeatable alignment.

### Key Features

- Preloaded for full reverse application
- Replaceable inserts for various specimen sizes
- Suitable for threaded and button-end specimen
- Low thermal gradient
- Available in various sizes suiting different furnace





## Fatigue Testing

The LFV Servohydraulic Test Systems are optimized to cover the full spectrum of dynamic and fatigue testing applications.

The modular construction and the comprehensive range of accessories enable the test system to be configured exactly according to your requirements.

Your test system works as efficiently as possible with the right combination of test actuator, precisely designed servo valve(s) and appropriate hydraulic power unit combined with the highly stiff load frame.

Our high accurate transducers combined with the high-resolution, ultra-high-speed **PCS8000** digital controller and alignment fixture provide accurate test execution and repeatable test results. Operated by our **DION7** software, these systems perform your dynamic and fatigue low-cycle to high-cycle tests of today and tomorrow. change.

### Typical Test Standards

- ASTM E466
- ISO 1099
- EN 6072
- ISO 12106
- BS 7270
- ASTM D3479.....

## Static Testing

Our Servohydraulic Multipurpose LFV Series are versatile test systems that meet in combination with our wide selection of grips and strain-measurement systems virtually any static materials testing needs.

Our reliable w+b servo-controlled hydraulic actuation with high-resolution & high-speed digital closed loop controls and **DION7STAT** static application software offers easy and productive testing with a large and growing library of test templates meeting specific international test standards including tensile, bending (flex), compression, shear and peel / tear tests on specimens such as Metals & Alloys, Composites, Plastics, Rubber, Biomedical Products, Concrete, Cements, Wood & Timber, Textiles & Fibres and more.

### Typical Test Standards

- ISO 6892-1
- ISO 6892-2
- ASTM E8
- ASTM E9
- ASTM E21
- GOST 1497
- ASTM C1275
- ISO 527-4
- ASTM D3039
- ISO 527-1.....

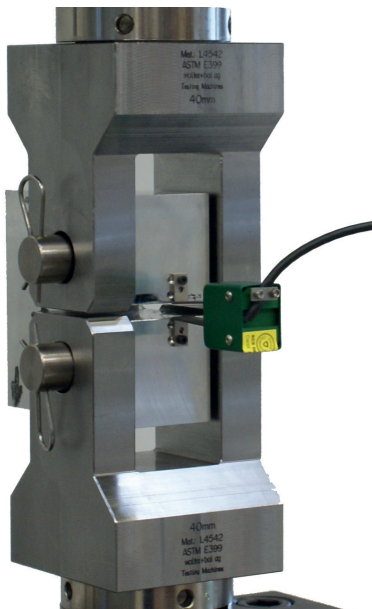

## Fracture Mechanics Testing

Our LFV systems can be readily configured to perform fracture mechanics testing. The load frame can be used for pre-cracking, fracture toughness and fatigue crack growth testing.

We are offering a selection of clevis grips, clip-on displacement gauges and readymade application software to ASTM, ISO and British test standards.

### Typical Test Standards

- ASTM E399
- ASTM E1820
- ASTM E647
- ISO 12135
- ISO 15653
- ASTM E561
- BS7448.....

### Tests

- Pre-Cracking
- Fracture Toughness
- Fracture Crack Growth
- Crack Propagation
- K<sub>Ic</sub>, J<sub>Ic</sub>

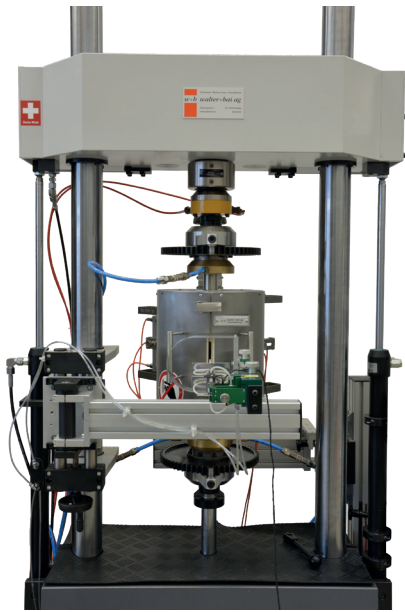

## Low Cycle Fatigue (LCF) Testing

These servohydraulic test systems are easily configured to perform low cycle fatigue tests from ambient to high temperature in accordance with different international standards including ASTM E606 and ISO 12106.

It comprises the seamlessly integrated grips, extensometer, and high temperature furnace for LCF Testing combined with carefully selected servo valve, vibration reducing machine pad, accessories for minimum thermal drift, and specialized **DION7LCF** low cycle fatigue application software that simplifies the test setup and run the test with real-time graphs and calculations with post-test analysis and data-export. With our alignment verification equipment, you will be sure you comply to the standard including NADCAP.

### Typical Test Standards

- ASTM E606
- ISO 12106

## Thermomechanical Fatigue (TMF) Testing

Our LCV systems are ideal to integrate ancillary equipment to support the requirements of Thermomechanical Fatigue Testing.

It comprises the seamlessly integrated inductive heating system, temperature measurement thermocouples and or pyrometer, water-cooled grips, low noise extensometer and **DION7TMF** application software module that contains all to perform in-phase or out-of-phase strain-controlled thermomechanical tests according to ASTM E2368 or ISO 12111 or force controlled thermo-mechanical fatigue testing according to ISO 23296 including report templates and data export.

With our alignment verification equipment, you will be sure you comply to the standard including NADCAP.

### Typical Test Standards

- ASTM E2368
- ISO 12111
- ISO 23296

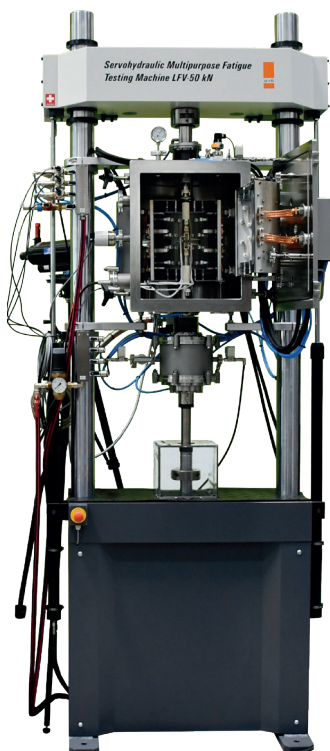
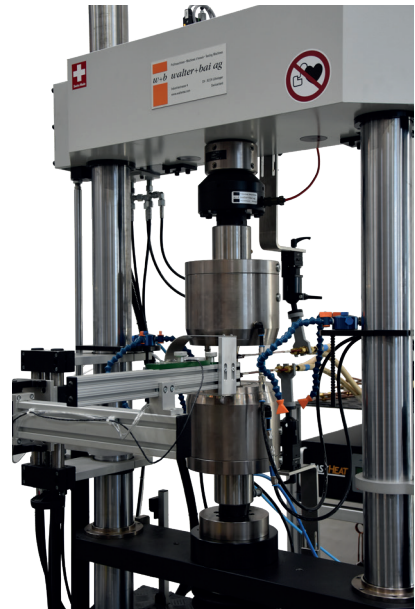

## High Temperature Testing under Vacuum / Inertgas

Our LCV systems can be configured to support the unique requirement of Materials Testing under High-Temperature Vacuum or Inertgas.

As tests requirements varies depending on materials to be tested and applied standard's the LCV system will be application optimized with seamlessly integrated vacuum / inert gas chamber and related accessories.

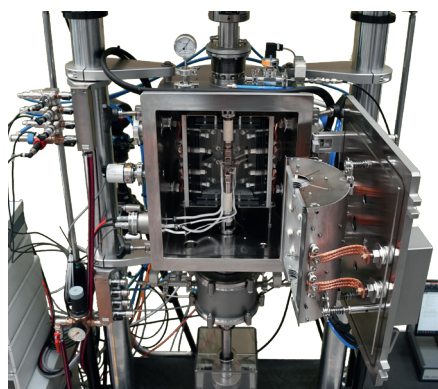

### Typical Test

- Tensile Testing
- Compression Test
- Flexural / Bending Tests
- LCF Tests
- Fracture Toughness
- Fatigue Crack Growth Test

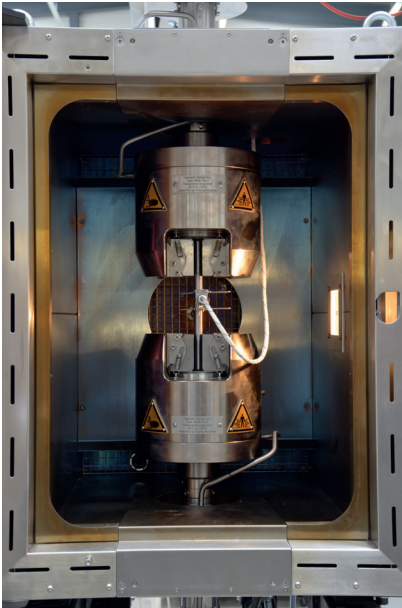

## Environmental Testing

Our versatile LFV systems are ideal to integrate seamlessly accessories needed to simulate in-service environmental conditions. The systems are prepared to accommodate high temperature furnace, environmental chamber with or without humidity control, corrosion-chamber, or any other environmental simulation unit with its suitable gripping system, extensometer, thermocouples, pyrometer, or other sensor technology.

### Typical Test Standards

- ISO 6892-2
- ASTM E8
- ASTM E466
- ASTM D3479
- ASTM D3916
- ASTM E606
- ASTM D6115
- ISO 12106
- ASTM E399, 1820, 647.....

## Composites Testing

Composite materials are used for most new aircraft designed structures, in the power and civil engineering, as part of automotive structures, or high temperature composites are incorporated into turbines.

Our LFV series allows to mount various of static and fatigue test fixtures. The accessories that fit our LFV's for the determination of the fatigue properties includes tension-tension, tension-compression, compression-compression, bending fatigue and fatigue crack growth. Beside of our aligned grips the LFV series with **PCS8000** digital controller and **DION7** software offers further useful features for composite testing like automatic frequency adjustment in relation with specimens' temperature, use of strain gauges with strain gauge bridge completion module and various clip-on, automatic and noncontact extensometers to full-field strain measurement in a wide temperature range. Test Systems for composite materials testing are available with application specific enclosures for customers and equipment safety.



### Typical Test Standards

- Various ASTM and ISO standards for static tensile, compression and shear testing
- ISO 13003
- ASTM D3479
- ASTM D3916
- ASTM D6115
- EN 6033
- EN 6034 .....

## Fastener Testing

Fasteners as bolts and nuts, screws, rivets, hooks and eyes play a critical role in many engineering structures. As their failure can result in significant consequences they are tested extensively including in static tension and shear direction to determine their mechanical properties and under fatigue loading. When additionally, to the static testing fatigue testing is part of the specification, as often required for fasteners used in aerospace or engines, the LFV fatigue test systems are well suited to perform this static to fatigue tests of all kinds of fasteners. The fatigue test methods are not limited to direct tension but also include other methods as for example single and double shear fatigue and tension-bending fatigue test methods for threaded airframe fasteners.

### Typical Test Standards

- ASTM F606
- ISO 898
- ISO 3506-1
- ISO 3800
- NASM1312-7
- ASTM E466



## High Temperature Testing with Electrical Resistive Heating



Our LFV test system are easily configured to accommodate electrical resistive high temperature heating system with or without inert gas chamber. These heating systems provide high speed direct specimen heating by passing a low frequency electrical current through a specimen.

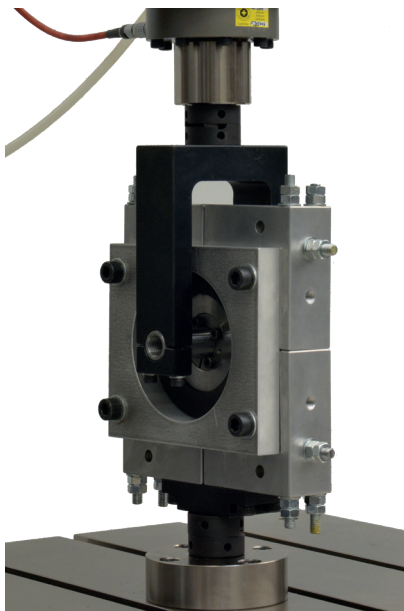

### Component Testing

Accessible LFV systems offers seamlessly integration of fixtures and working tools for both static and dynamic component testing. The expandable system can be equipped with accessories for multiple-position deformation measurement, temperature measurement, internal pressure measurement or any other.

**DION7EASY** and **DION7FPI** application software provides everything from easy-to-use, intuitive, and highly visual environment to run single function tests to free programming event depending complex component tests.

### Typical Standards

Various ISO, ASTM, FDA, DIN, GOAST and company internal test standards

## Everything from a Single Source

Thanks to our decades of experience in testing machine construction, maintenance and calibration, we can offer you an all-round service for your testing machines and systems. This minimizes failures and ensures compliance with standards. We offer preventive maintenance, on-site repairs, overhauls and repairs in our factory, machine relocations and recommissioning, spare parts, software updates & upgrades, training and modernizations.

## More than 50 Years Experience

Owing to over 50 years of experience in the production of electromechanical test systems our servohydraulic test systems includes a numerous of features and achievements guaranteeing operational efficiency, safety and reliable testing with minimum down-time.

## Modular & Flexible

The modular design enables us to adapt these tests systems to virtually any of your requirements. Common customizations include:

- Other test speeds
- Extended vertical or horizontal test spaces
- Multifunctional T-slot base platen to clamp grips or fixtures, components or finished goods
- Additional second working space
- Extending to fully automatic robotic system

