

Application

Servohydraulic Fastener Testing Machine Type TTM 1200 kN

pecially designed for testing
of fasteners size M3 to M33
according to ISO 898-1, ASTM F606 a.s.o.

Features:

- The double acting actuator with extra long piston stroke is integrated in upper crosshead.
- The upper crosshead is mechanically movable.
- PC Table with digital controller Series EDC and PC with Material Testing Software **DIONSTAT** for automatic testing procedure in closed loop control, data acquisition and print-out of test results.
- Integrated fastener testing grips Series FTG to accept various exchangeable inserts for round specimen with shoulder or thread-heads.
- Separate free standing hydraulic power pack.

Customer: Alcoa Fastening Systems, FR - Toulouse

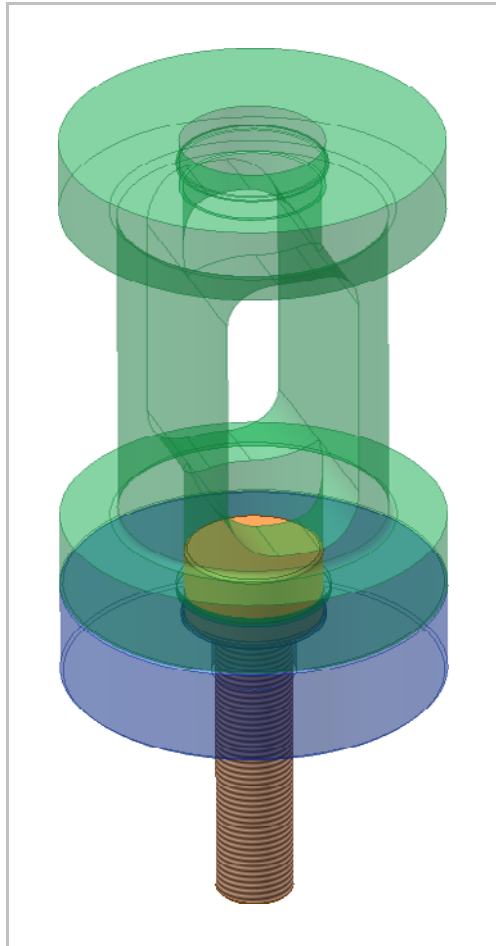

w+b



walter+bai ag Testing Machines

Industriestrasse 4, 8224 Löhningen, Switzerland, Tel. +41 (0)52 687 25 25, Fax +41 (0)52 687 25 20
E-Mail: info@walterbai.com / Internet: <http://www.walterbai.com>