

General Purpose Axial Extensometers Series 3542

The 3542 Series are general purpose strain gage extensometers for axial tensile, compression, and cyclic testing. They are available with various gauge lengths, measuring & temperature ranges.

Gauge lengths are available from 10 mm to 80 mm (and 0.5 to 2 inches) and full-scale measuring ranges from 5% to 100% strain.

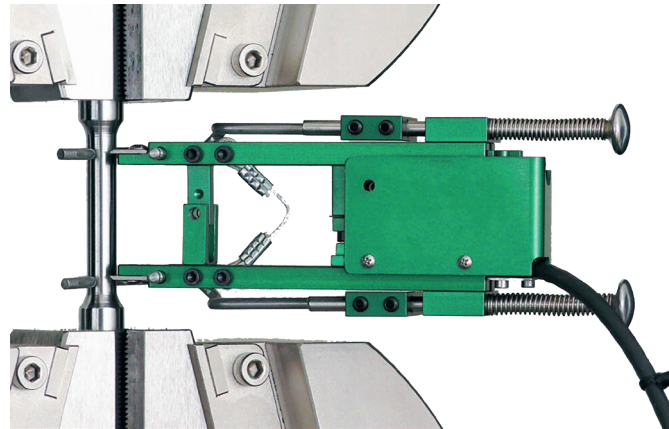

These extensometers are designed for testing a wide range of materials, including metals, plastics, composites and ceramics. All will perform both tension and compression strain measurement.

The dual flexure design makes them very rugged and insensitive to vibrations, which permits higher frequency operation.

They come standard with quick attach kit, making it possible to mount the extensometer on the test specimen quickly and easily with one hand. The quick attach kit can be removed, allowing mounting of the extensometer with springs or rubber bands. The Series 3542 extensometers are strain gauged devices.

Model 3542 extensometers are applicable for testing with the following standards:

- ISO 6892-1, 527-2, 527-4, 527-5, 10113
- ASTM E8, E9, D3039, D638, A370, D3552, E517, E646

The Model 3542 extensometers are strain gaged devices, making them compatible with any electronics designed for strain gaged transducers. For gauge lengths less than 20 mm (0.8 inches), we recommend the more compact Model 3442. For gauge lengths 100 mm (4 inches) or greater see Model 3542L.

Features

- May be left on through specimen failure
- All standard units meet existing ISO 9513, class 0,5 and ASTM class B-1 requirements for accuracy.
- Applicable for testing to:
 - ISO 6892-1, ISO 527-2, ISO 527-4, ISO 527-5, ISO 10113
 - ASTM E8, E9, D3039, D638, A370, D3552, E517, E646
- All models can measure in both tension and compression and can be used for cyclic testing.
- Full bridge, 350 ohm strain gauged design
- Standard quick attach kit allows one hand mounting to specimens.
- Rugged, dual flexure design for strength and improved performance. Much stronger than single flexure designs, this also allows cyclic testing at higher frequencies.
- All models have mechanical overtravel stops in both directions. Cable stops are used for overtravel protection where required. Epsilon's cable stops are fully contained between the arms of the extensometer and do not hang below where they can interfere with fixturing – especially during compression testing.
- Hardened tool steel knife edges are easily replaced
- Gauge length adapter kits enable configuration of multiple gauge lengths with one extensometer.
- High and low temperature options extend operation from as low as -265 °C to +200 °C
- Replaceable arms and spacers for ease of repair. This also allows changing the gage length for different test requirements
- Includes high quality foam lined case

Specification:

Excitation:	5 to 10 VDC, recommended, 12 VDC or VAC max.
Output:	2 to 4 mV/V, nominal, depending on model
Linearity:	≤0.15% of full scale measuring range
Temperature Range:	Standard (-ST) is -40°C to +100°C to -265°C to +200°C (-LHT)
Cable:	Integral, ultra-flexible cable, 2.5 m standard (longer available)
Standard Quick Attach Kit:	Fits round samples up to 25 mm diameter (1.0 inch) and flats to 12 mm thick by 31 mm wide (0.5 inch by 1.25 inch)
Operating Force:	30 g typical

Options:

- Quick attach kit wire forms for large specimens
- Adapter kits to change gage lengths
- Specialty knife edges
- Special coatings and stainless steel knife edges available for biomedical tests

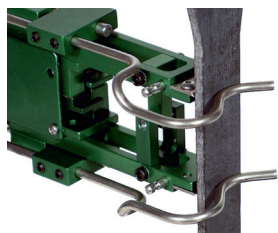

Standard quick attach wire forms included for round and flat samples

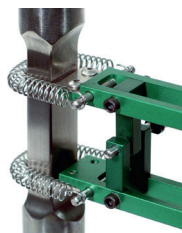
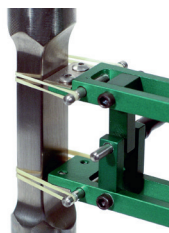

Rubber band and spring attachment options included with models 3542 and 3442

Technical Data

Model 3542 Available Versions: ANY combination of gauge length, measuring range and temperature range listed below is available, except as noted. *Other configurations may be available with special order; please contact Epsilon to discuss your requirements.*

Model Number 3442	010M	005	LT
Gage Length			
Travel			
Temperature Ranges			

Gage Length:	
-010M	10.0 mm
-012M ¹	12.0 mm
-0125M ¹	12.5 mm
-020M	20.0 mm
-025M	25.0 mm
-050M	50.0 mm
-080M	80.0 mm

Measuring Range ¹ (Travel)	
-005M ²	±0.5 mm
-010M	±1.0 mm
-020M	+2.0 mm/-1.0 mm
-025M	+2.5 mm/-1.0 mm
-050M	+5.0 mm/-1.0 mm
-100M	+10.0 mm/-1.0 mm

Temperature Ranges:		
Low	LT	- 270°C to + 100 °C
Standard	ST	- 40 °C to + 100 °C
High 1	HT1	- 40 °C to + 150 °C
High 2	HT2	- 40 °C to + 200 °C
Low-High	LHT	-270 °C to + 200 °C

¹ Compressive ranges can be adjusted to higher values if required.

Please contact Epsilon for your specific testing requirement

² Not available in 10 mm, 12.5 mm, or 0.50 inch gauge lengths.

Standard Knife Edges

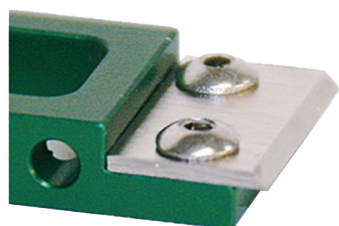

PART NO. 350210-01

Produced from hardened tool steel, these knife edges are used for a wide range of applications, and can be used on both round and rectangular shaped specimens. These are the standard knife edges supplied with 3542 extensometer.

w+b Materials Testing Systems

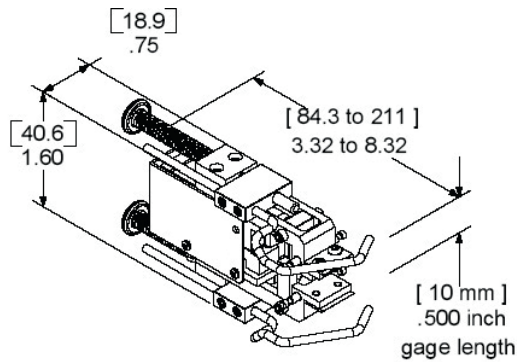

3542 LOW MEASURING RANGE

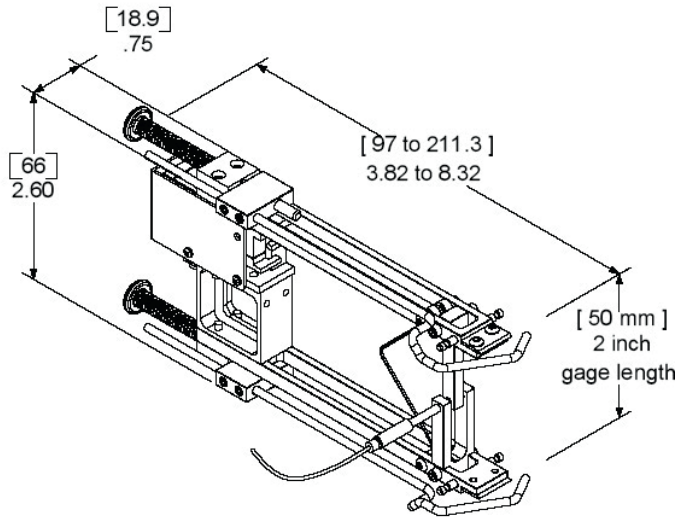

3542 HIGH MEASURING RANGE

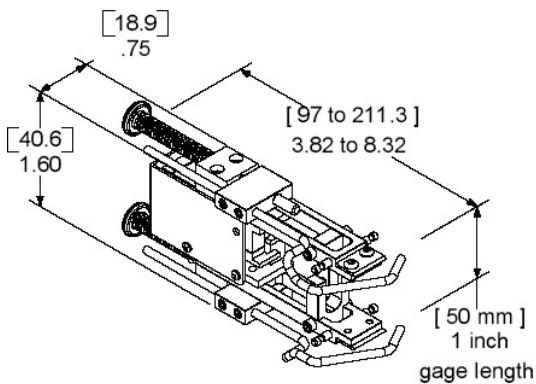

3542 MEDIUM MEASURING RANGE

DIMENSIONS: [mm] inches

Extensometers for Composites Compression Testing

Models 3542 and 3442 extensometers can be furnished to clip directly onto composites compression fixtures, such as for ASTM D695. These use specially made quick attach kit wire forms for the test fixture. Consult the factory for specifics.

Also see the Model 3442 miniature extensometer

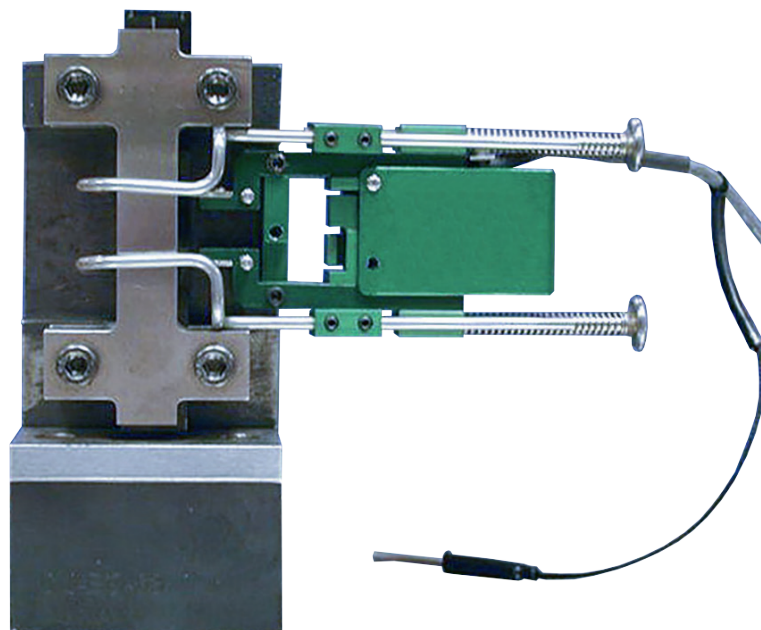

walter+bai ag · Industriestrasse 4 · 8224 Löhningen · Switzerland

Tel. +41 (0)52 687 25 25 · Fax +41 (0)52 687 25 20 · info@walterbai.com · www.walterbai.com